

# JAKOBSEN

## DIAGRAM DIAGRAMM



**SJ824/1026/1032/1424/1432/1832**

**AC MACHINE**

SWU04+SIM02 (1992-2002)

**Jakobsen Planslibemaskiner ApS  
DK- 7100 Vejle, Denmark**

Telephone: (+45) 36 77 62 22  
[www.bastogco.com](http://www.bastogco.com)  
[Service@jakobsen-dk.dk](mailto:Service@jakobsen-dk.dk)

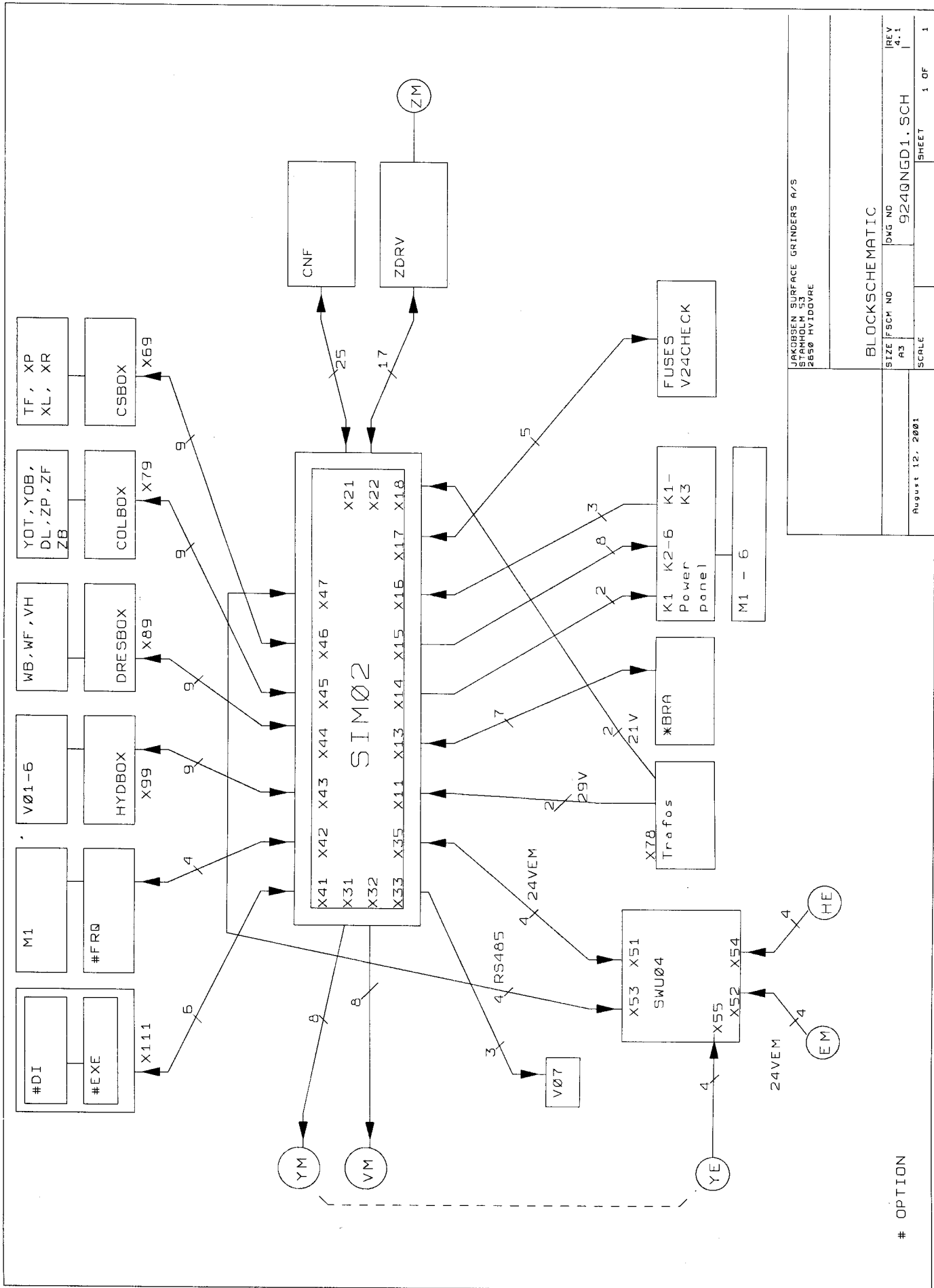

JAKOBSEN SURFACE GRINDERS A/S  
 STAMHOLM 53  
 2650 HVIDOVRE

BLOCKSCHEMATIC

SIZE	FSCM NO	DMG NO	REV
A3		9240NGD1. SCH	4.1
SCALE			SHEET 1 OF 1

# OPTION

August 12. 2001

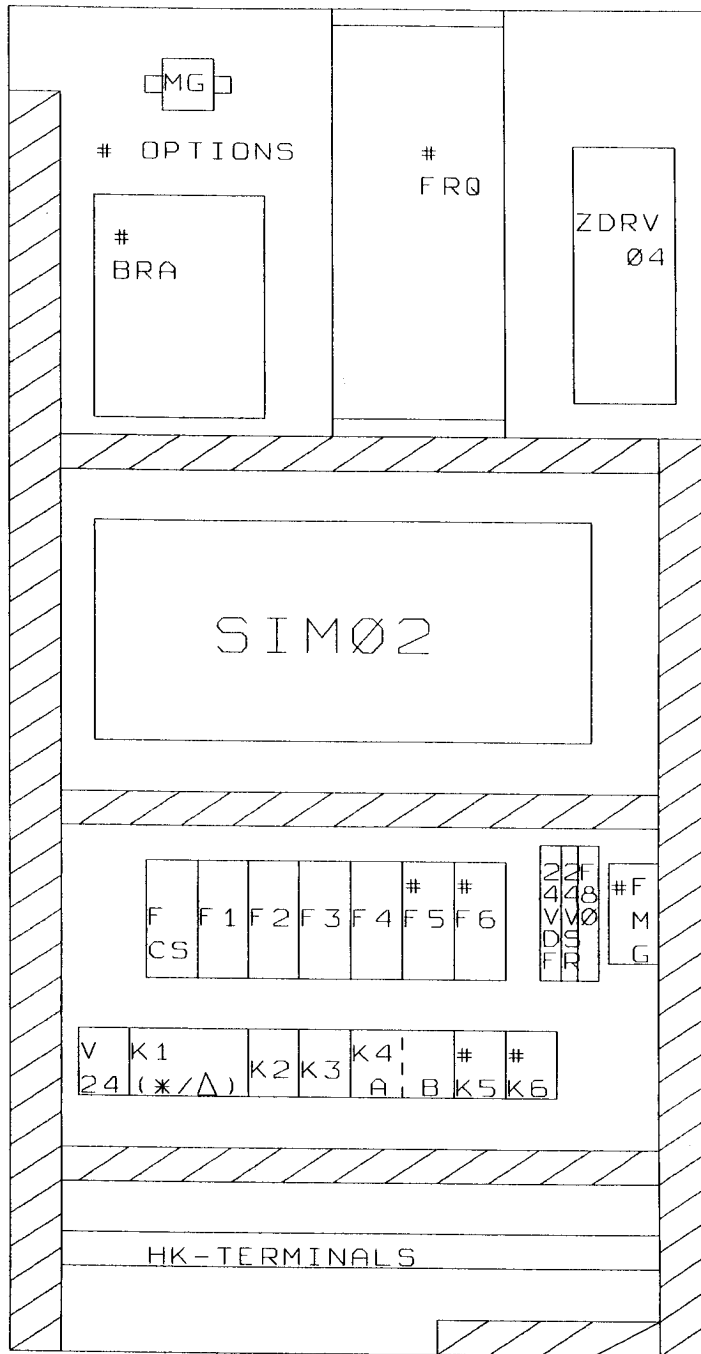

JAKOBSEN SURFACE GRINDERS A/S STAMHOLMEN 53 2650 HVIDOVRE			
POWER PANEL LAYOUT			
SIZE A2	FSCM NO	DWG NO 920#E2TG. SCH	REV 13.1
August 12, 2001	SCALE	SHEET	1 OF 27

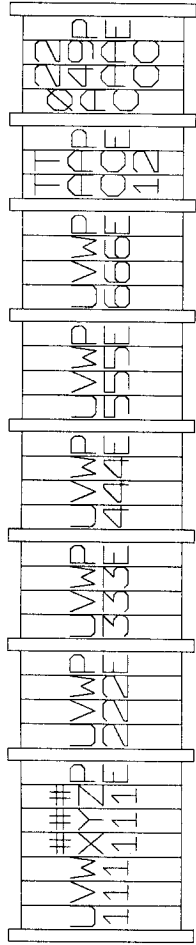
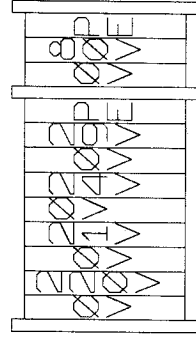

# 1832

JAKOBSEN SURFACE GRINDERS A/S  
 STAMHOLMEN 53  
 2650 HYDROVRE

HK-TERMINALS  
 LAYOUT

August 12, 2001	SCALE	9240G XKV. SCH	REV 3.1
	SIZE A3	DWG NO 2	2 OF 27
			SHEET

1 | 2 | 3 | 4 | 5 | 6 | 7 | 8 | 9 | 10 | 11 | 12 | 13 | 14 | 15

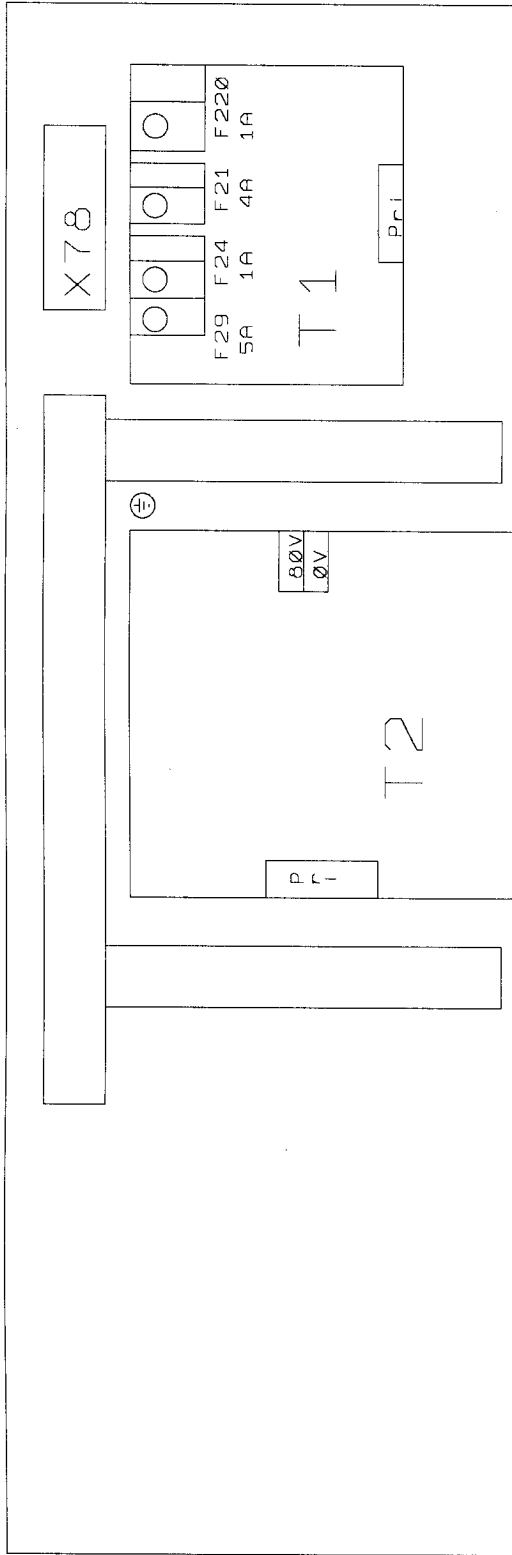

JAKOBSEN SURFACE GRINDERS A/S STAMHOLMEN 53 2650 HVIDOVRE			
TRAFOS, LAYOUT			
SIZE A3	FSCM NO	DWG NO 9371987G.SCH	REV 3.1
August 5. 2001	SCALE	SHEET 3 OF	27

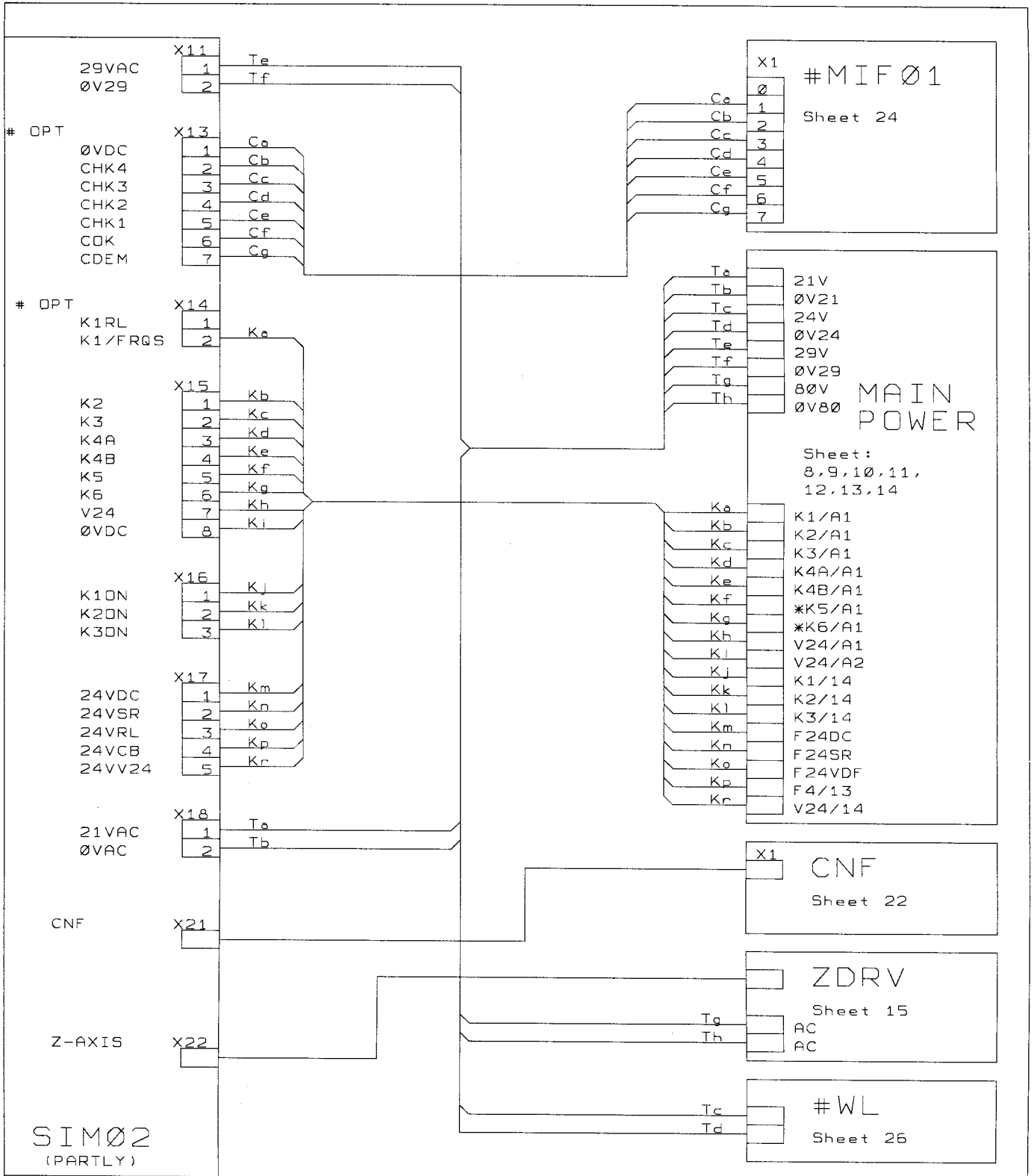

JAKOBSEN SURFACE GRINDERS A/S  
 STAMHOLMEN 53  
 265Ø HVIDOVRE

BLOCK SCHEMATIC, PART 1, AC

SIZE A1	FSCM NO	DWG NO 953T7#KM. SCH	REV 3.1
August 12. 2001	SCALE	SHEET 4 OF 27	

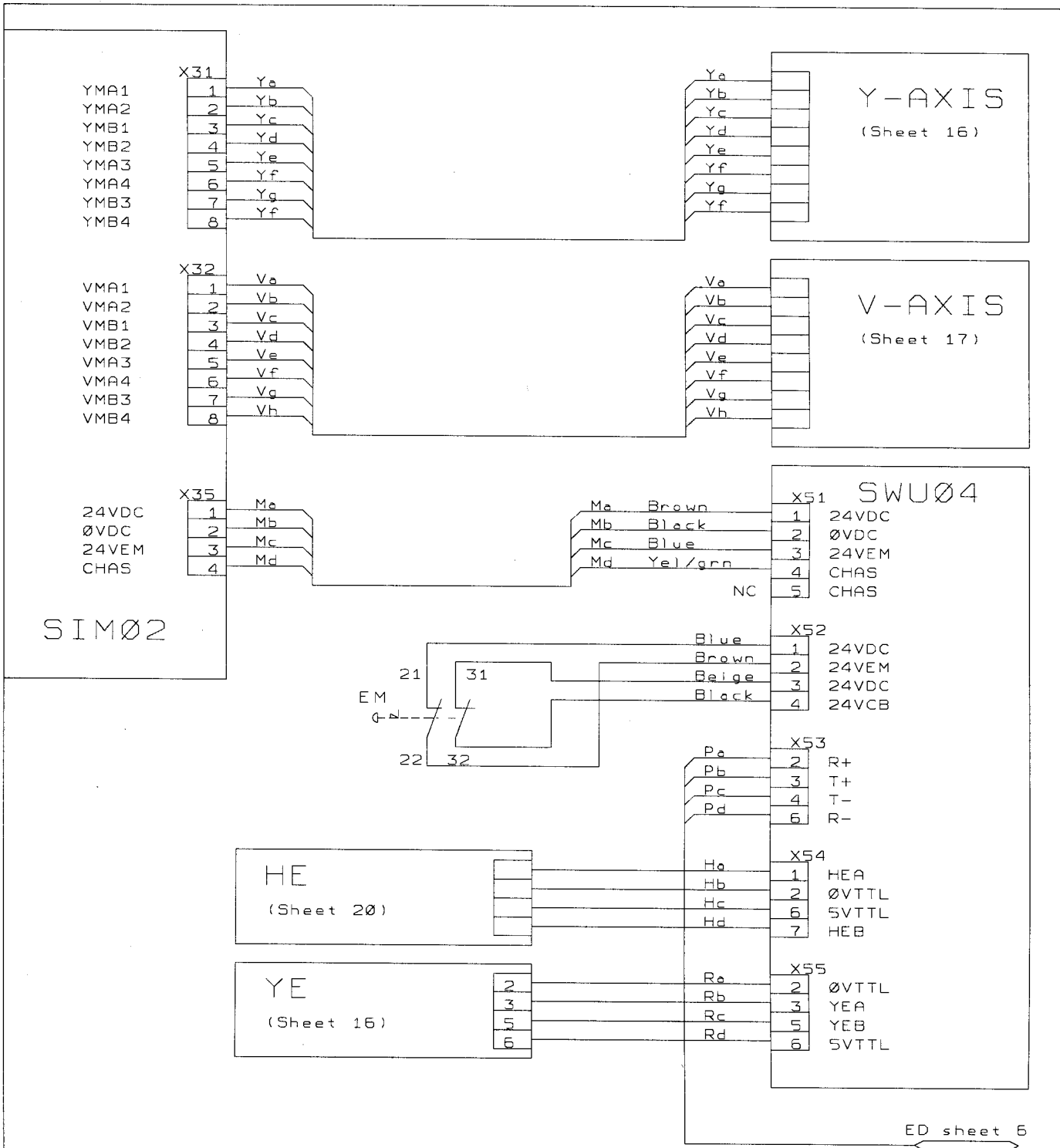

JAKOBSEN SURFACE GRINDERS A/S STAMHOLMEN 53 2650 HVIDOVRE			
BLOCK SCHEMATIC PART 2, AC			
SIZE A1	FSCM NO	DWG NO 953T7@RB. SCH	REV 3.1
August 5, 2001	SCALE	SHEET	5 OF 27

ED sheet 5

# DI  
(Sheet 23)

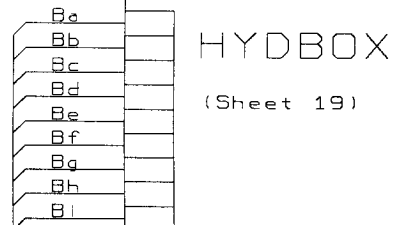
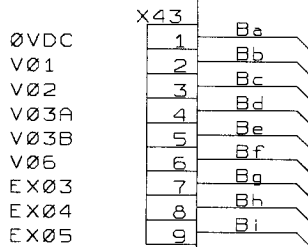
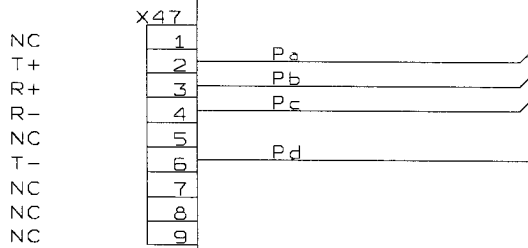
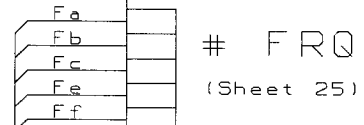
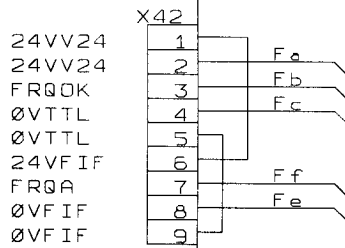
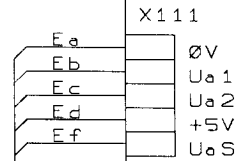
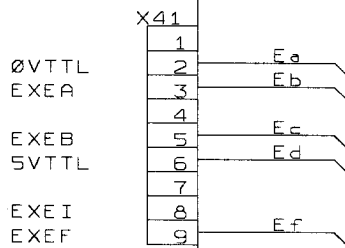

SIMØ2  
(PARTLY)

JAKOBSEN SURFACE GRINDERS A/S  
STAMHOLMEN 53  
2650 HVIDOVRE

BLOCK SCHEMATIC PART 3, AC

SIZE A1	FSCH NO	DWG NO	REV 3.1
August 12, 2001		953T7@X0.SCH	
SCALE		SHEET	6 OF 27



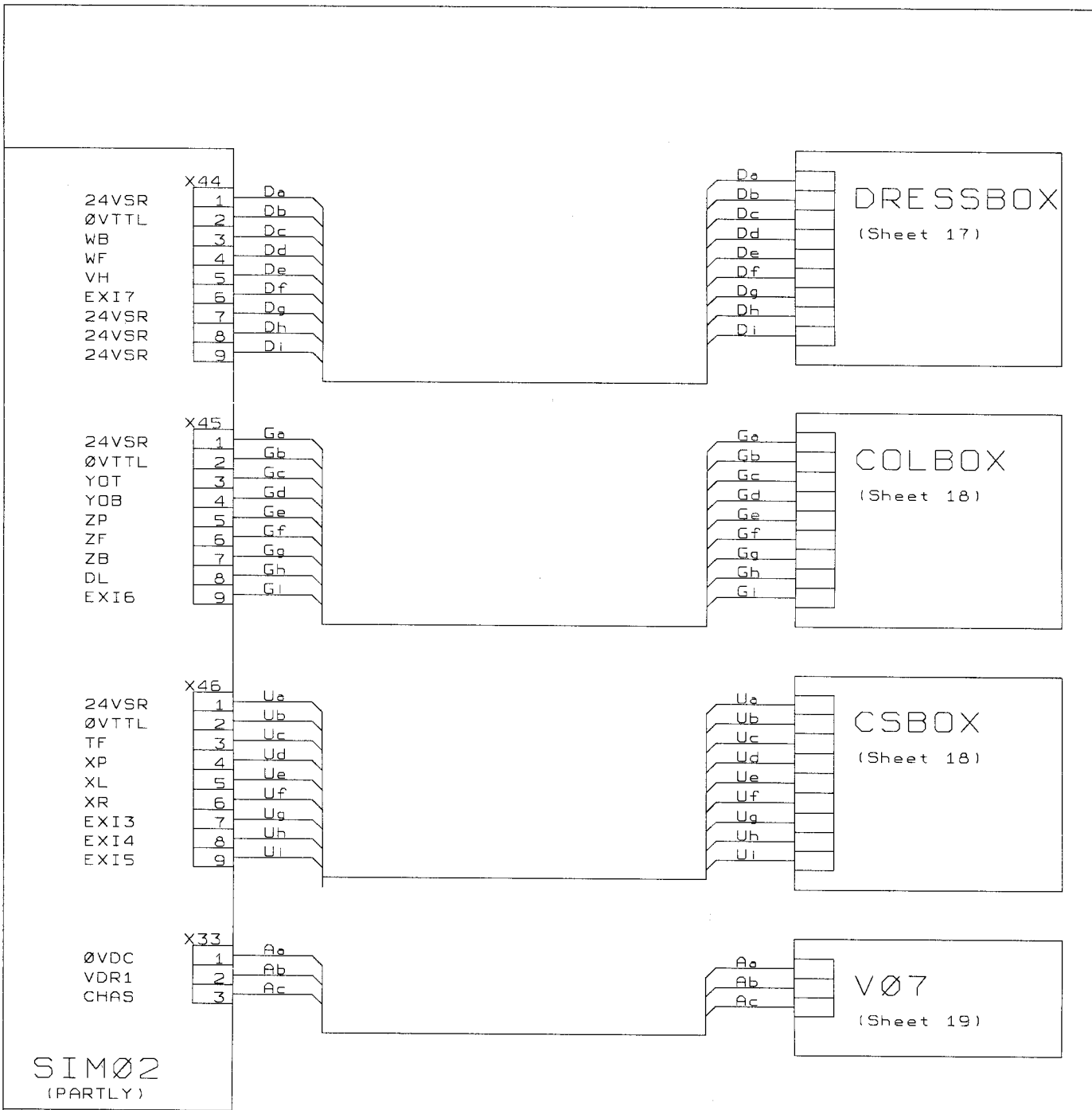

JAKOBSEN SURFACE GRINDERS A/S STAMHOLMEN 53 2550 HVIDOVRE			
BLOCK SCHEMATIC PART 4, AC			
SIZE A1	FSCM NO	DWG NO 9544AU5P.SCH	REV 3.1
August 5, 2001	SCALE	SHEET	7 OF 27

1 2 3 4 5 6 7 8 9 10 11 12 13 14 15

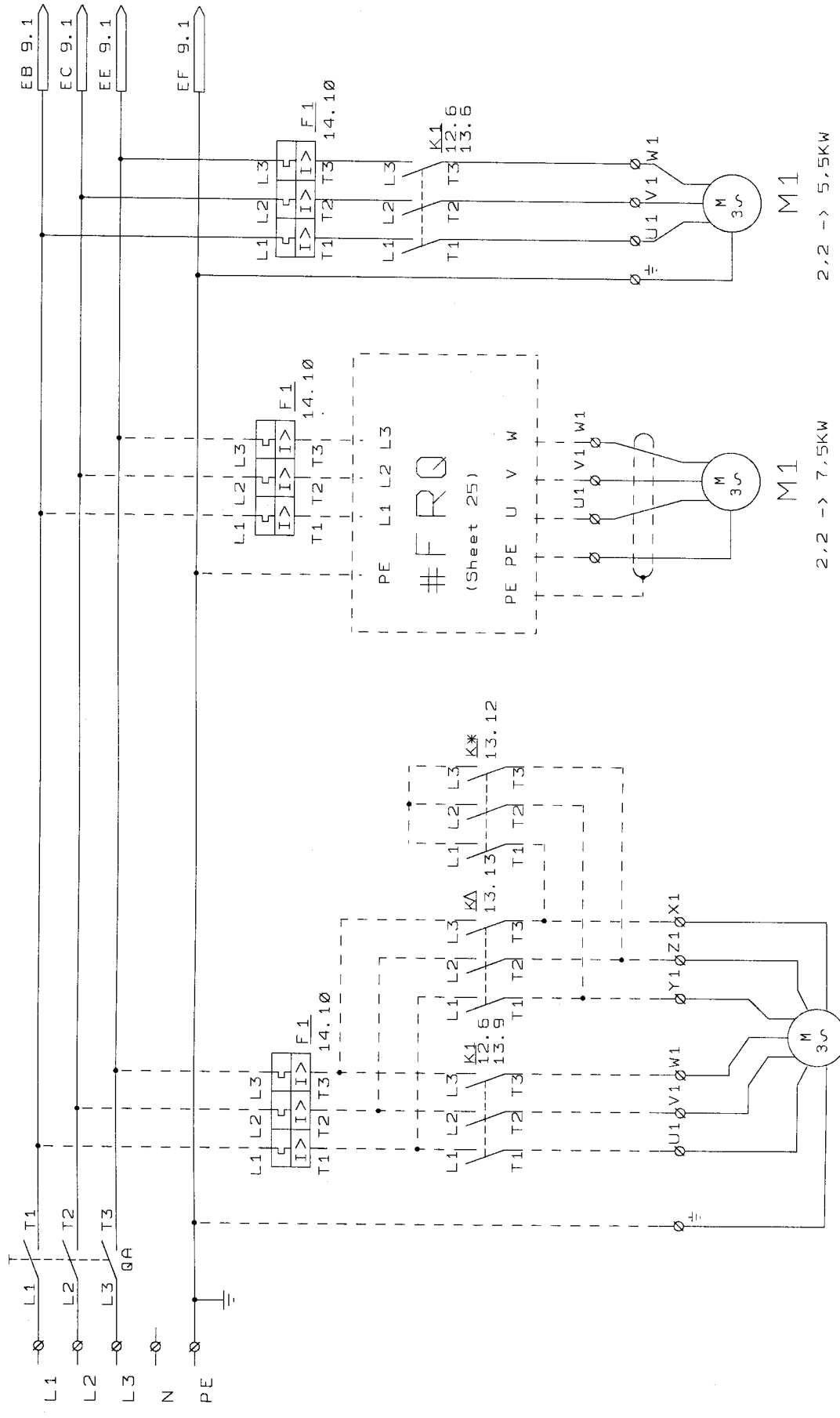

KARSEN SURFACE GRINDERS A/S STAMMEN 2650 HVIDVRE	
MAIN POWER, PART 1 (M1)	
SIZE FSCM NO A3	DWG NO 92UP I.D.SCH
August 15, 2001	SCALE
	SHEET 6 OF 27

2,2 -> 7,5KW

2,2 -> 5,5KW

7,5KW

# OPTION

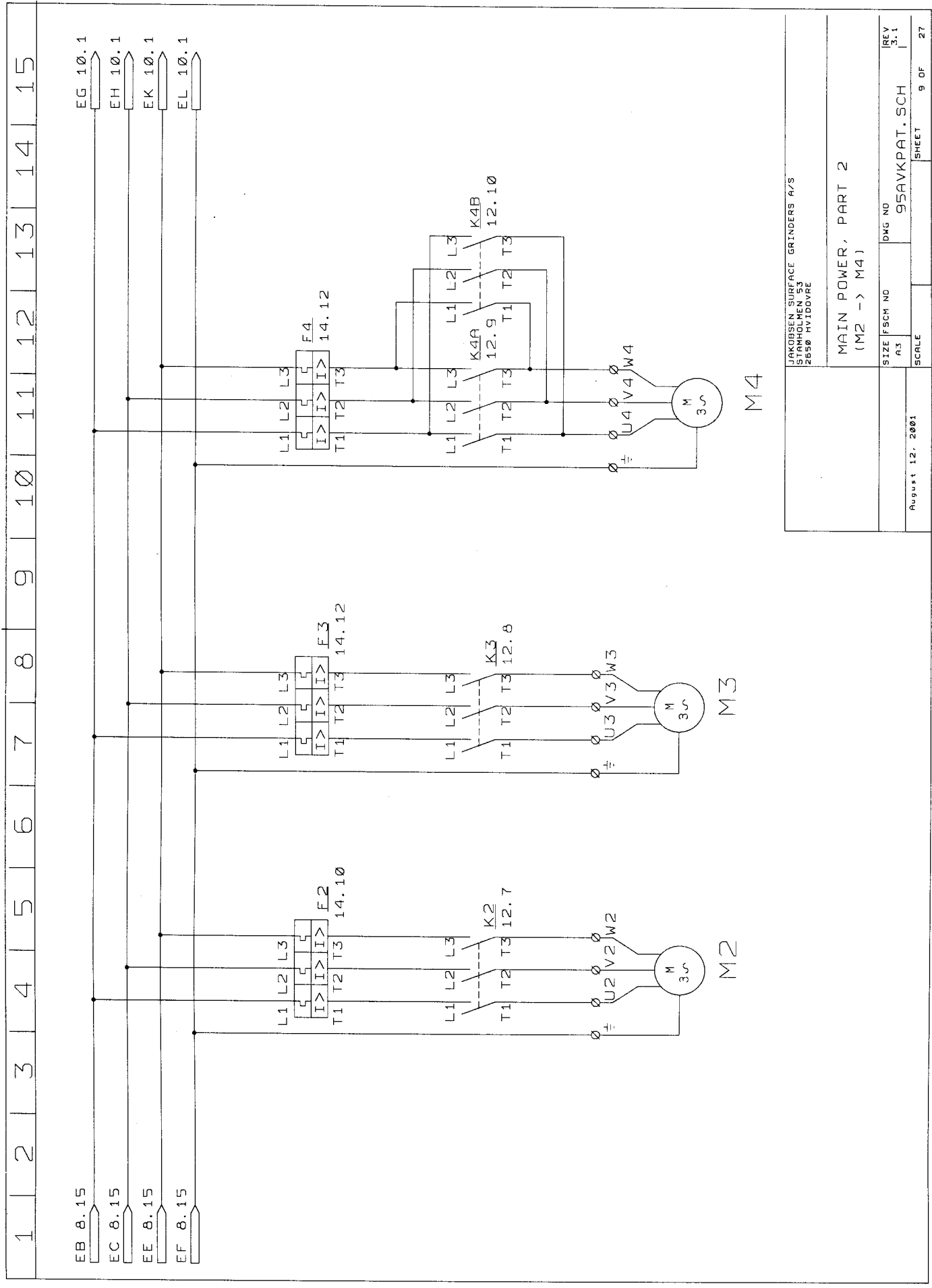

JAKOBSEN SURFACE GRINDERS A/S  
 STRANDHOLMEN 53  
 2656 HVIDovre

MAIN POWER, PART 2  
 (M2 -> M4)

August 12. 2001	SIZE	FSCM NO	DWG NO	REV
	A3		95AVKPAT. SCH	3.1
	SCALE			
			SHEET	9 OF 27

1 2 3 4 5 6 7 8 9 10 11 12 13 14 15

EG 9.15  
 EH 9.15  
 EK 9.15  
 EL 9.15

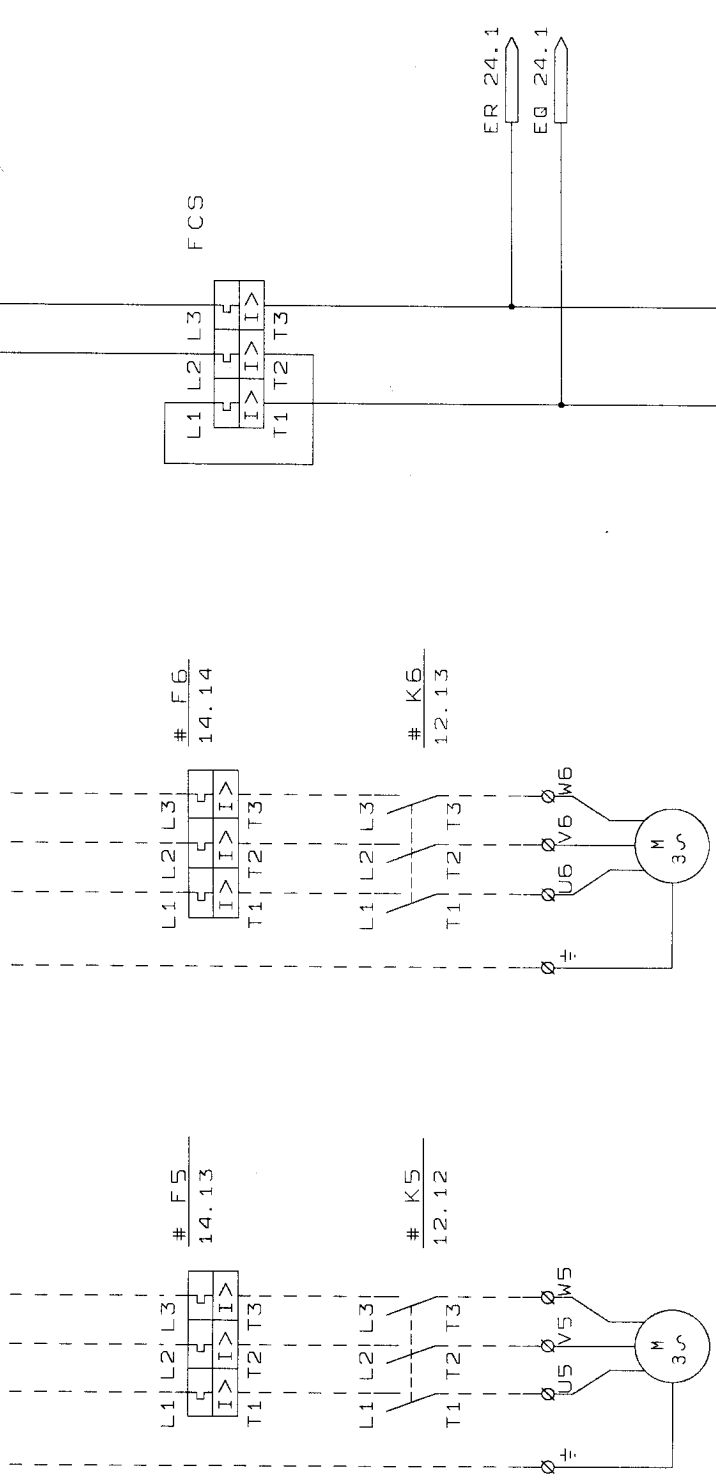

# M5 # M6

JAKOBSEN SURFACE GRINDERS A/S STAMHOLMEN 53 2650 HVIDOVRE	
MAIN POWER, PART 3 (M5, M6 + FCS)	
SIZE A3	FSCM NO 92UPB3#I. SCH
SCALE August 12, 2001	DWG NO 92UPB3#I. SCH
SHEET 10 OF	REV 3.1
	27

# OPTION

1 2 3 4 5 6 7 8 9 10 11 12 13 14 15

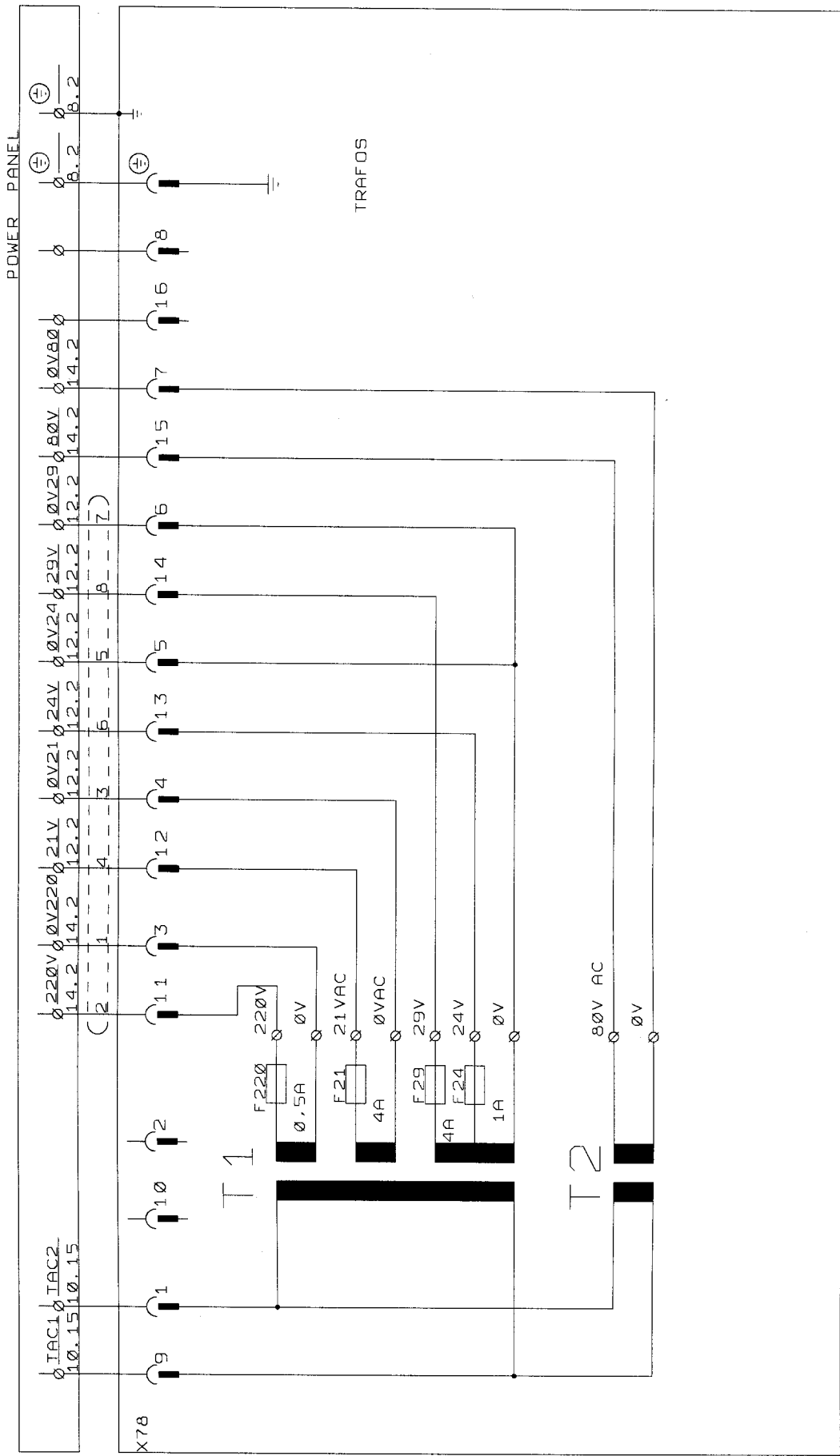

JAKOBSEN SURFACE GRINDERS 4/5  
 2658 HV100VRE

TRAFOS

SIZE	FSCB NO	DWG NO	REV
	A3	93803W3A.SCH	3.1
SCALE			SHEET 11 OF 27
August 12, 2001			

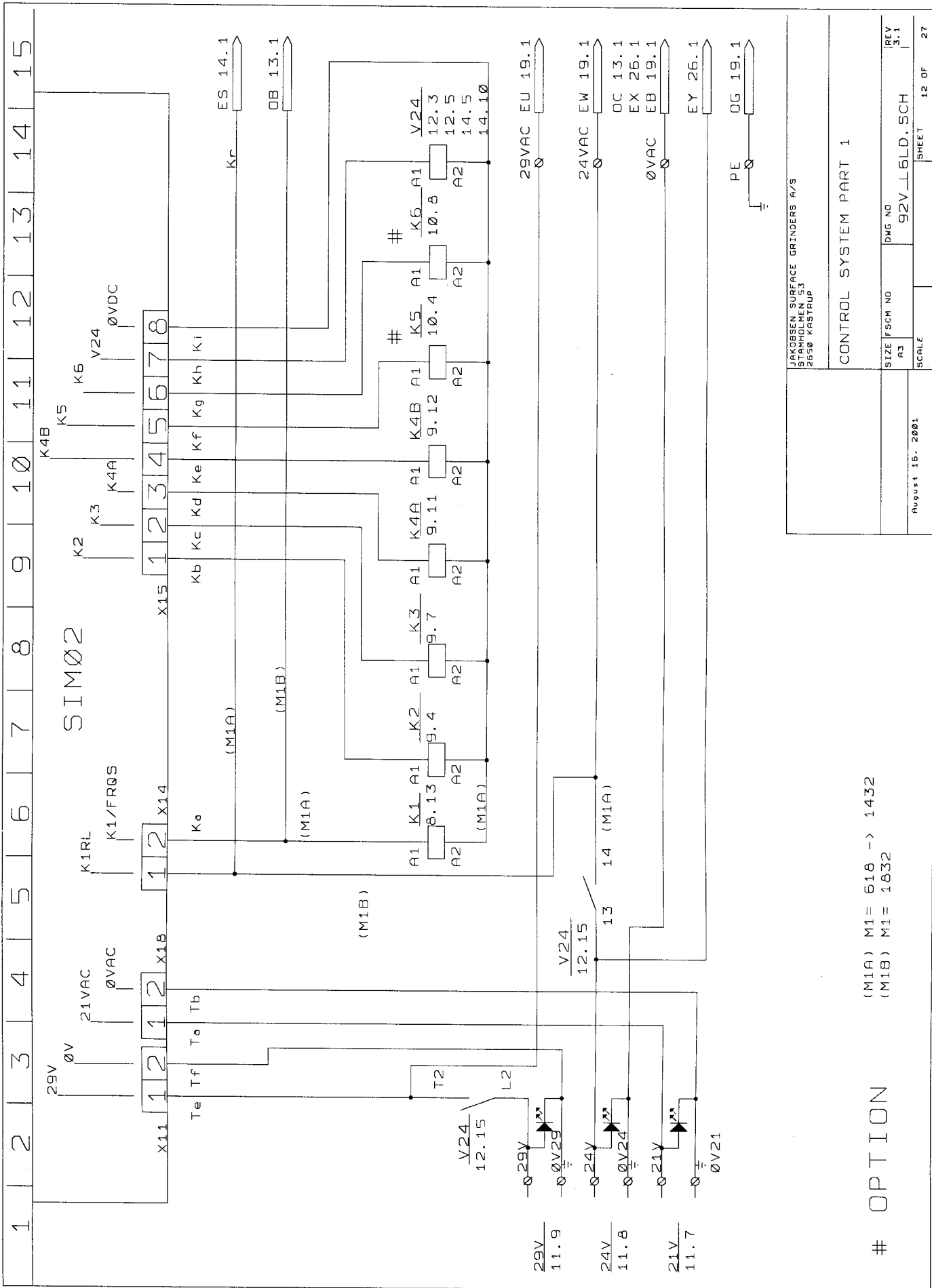

JAKOBSEN SURFACE GRINDERS A/S  
 STAMHOLMEN 53  
 2650 KASTRUP

CONTROL SYSTEM PART 1

August 16. 2001	SCALE	DWG NO	REV
		92VLL6LD.SCH	3.1
		SHEET	12 OF 27

(M1A) M1= 618 -> 1432  
 (M1B) M1= 1832

# OPTION

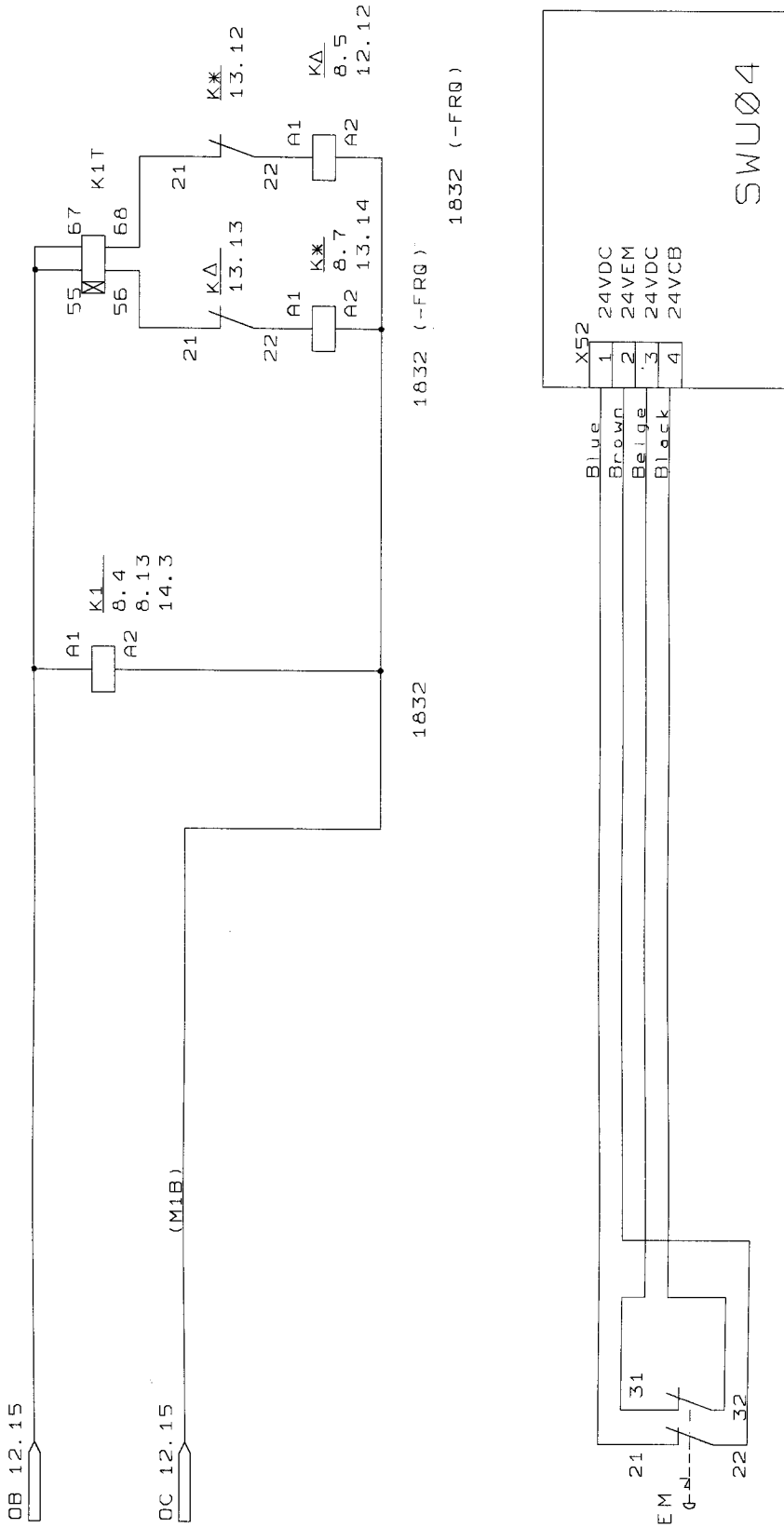

JAKOBSEN SURFACE GRINDERS A/S STAMHOLMEN 53 2650 HVIDOVRE		CONTROL SYSTEM PART 2	
SIZE A3	IFSCM NO	DWG NO 95V_U4FH.SCH	REV 3.1
August 12, 2001	SCALE	SHEET 13 OF 27	

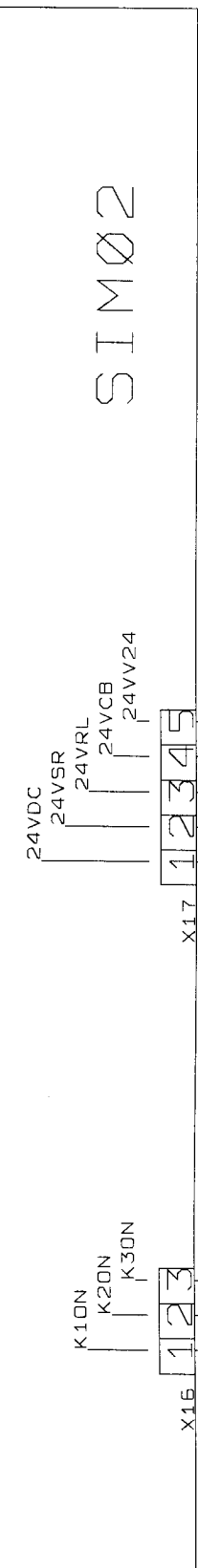

# SIMØ2

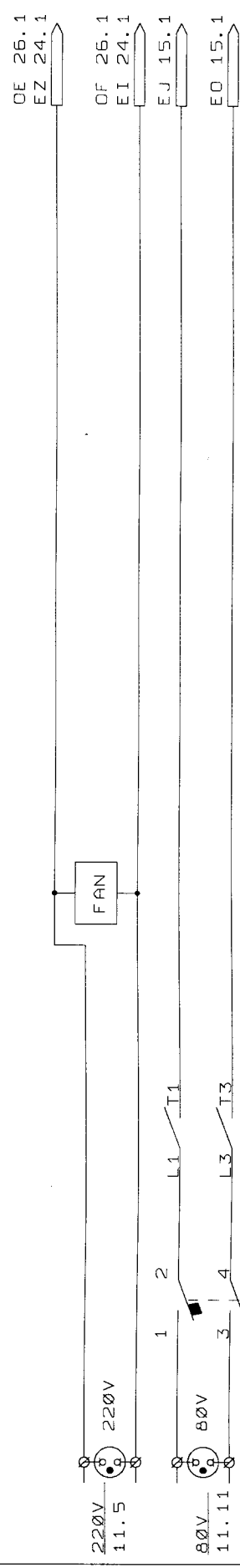
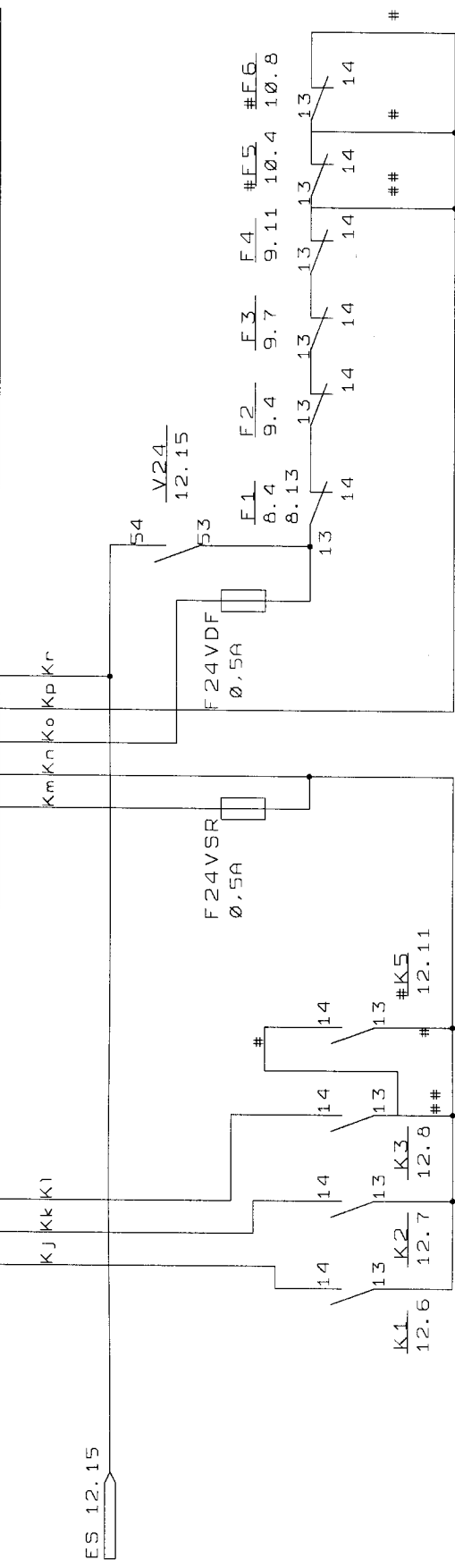

JAKOBSEN SURFACE GRINDERS A/S STAMHOLMEN 53 2850 HVIDOVRE			
CONTROL SYSTEM PART 3			
August 12. 2001	SIZE A3	FSCM NO	DWG NO
			92V_SNHC. SCH
		SCALE	SHEET 14 OF 27
			REV 3.1

# + K5/K6  
# # - K5/K6



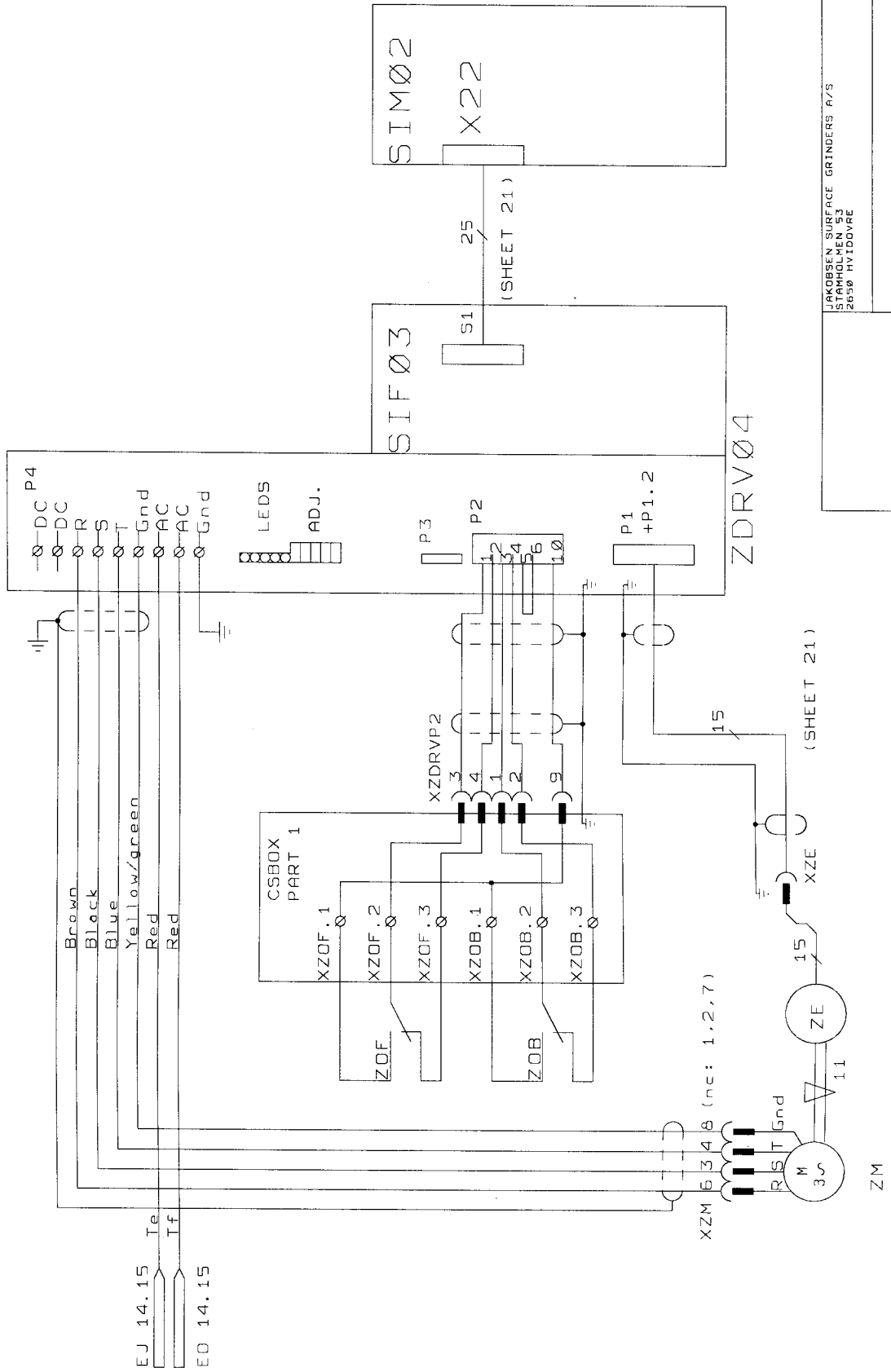

August 12, 2001		SCALE		
SIZE	FSCM NO	DWG NO	REV	
A3		9205WSIK.	SCH	
August 12, 2001		SCALE		
SHEET		15 OF		27

JAKOBSEN SURFACE GRINDERS A/S  
 STAMHOLMEN 53  
 2650 HVIDOVRE

Z-AXIS

1 2 3 4 5 6 7 8 9 10 11 12 13 14 15

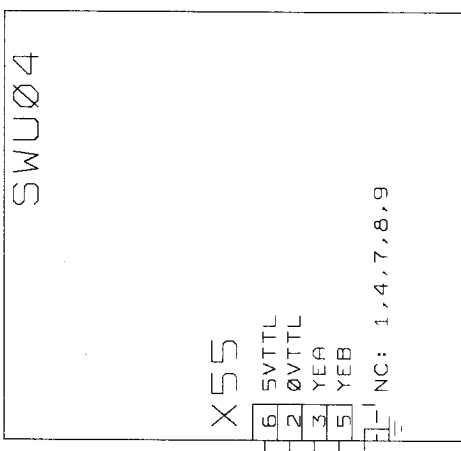
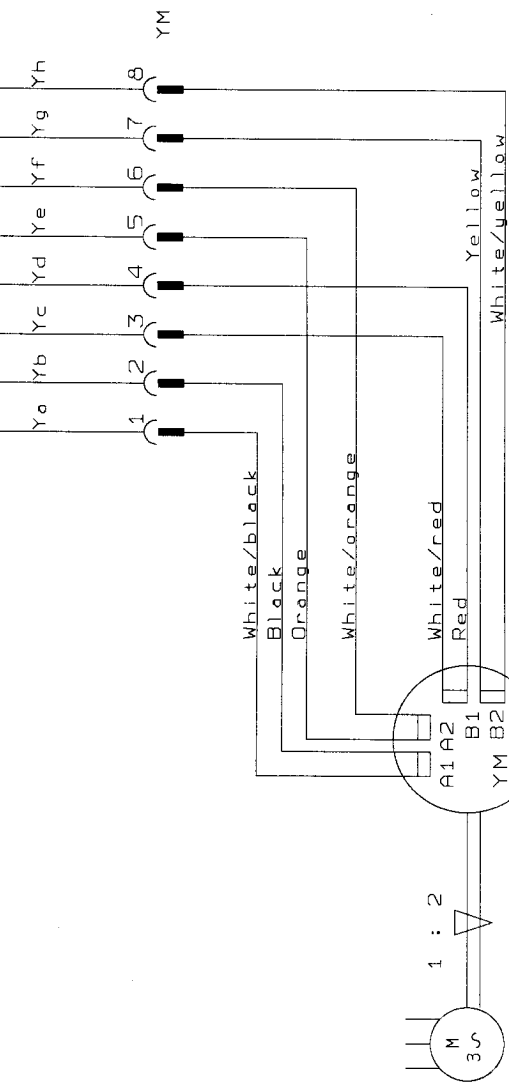
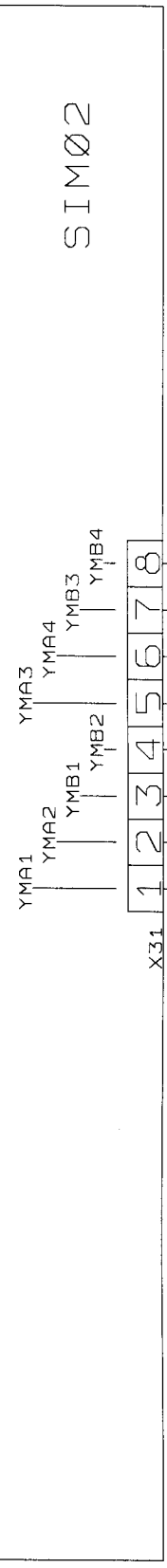

JAKOBSEN SURFACE GRINDERS A/S STAMHOLMEN 53 2650 HVIDOVRE			
Y-AXIS		DWG NO	REV
SIZE	FSCM NO	92VG308H. SCH	3.1
A3	SCALE	SHEET	16 OF 27
August 5. 2001			

1 2 3 4 5 6 7 8 9 10 11 12 13 14 15

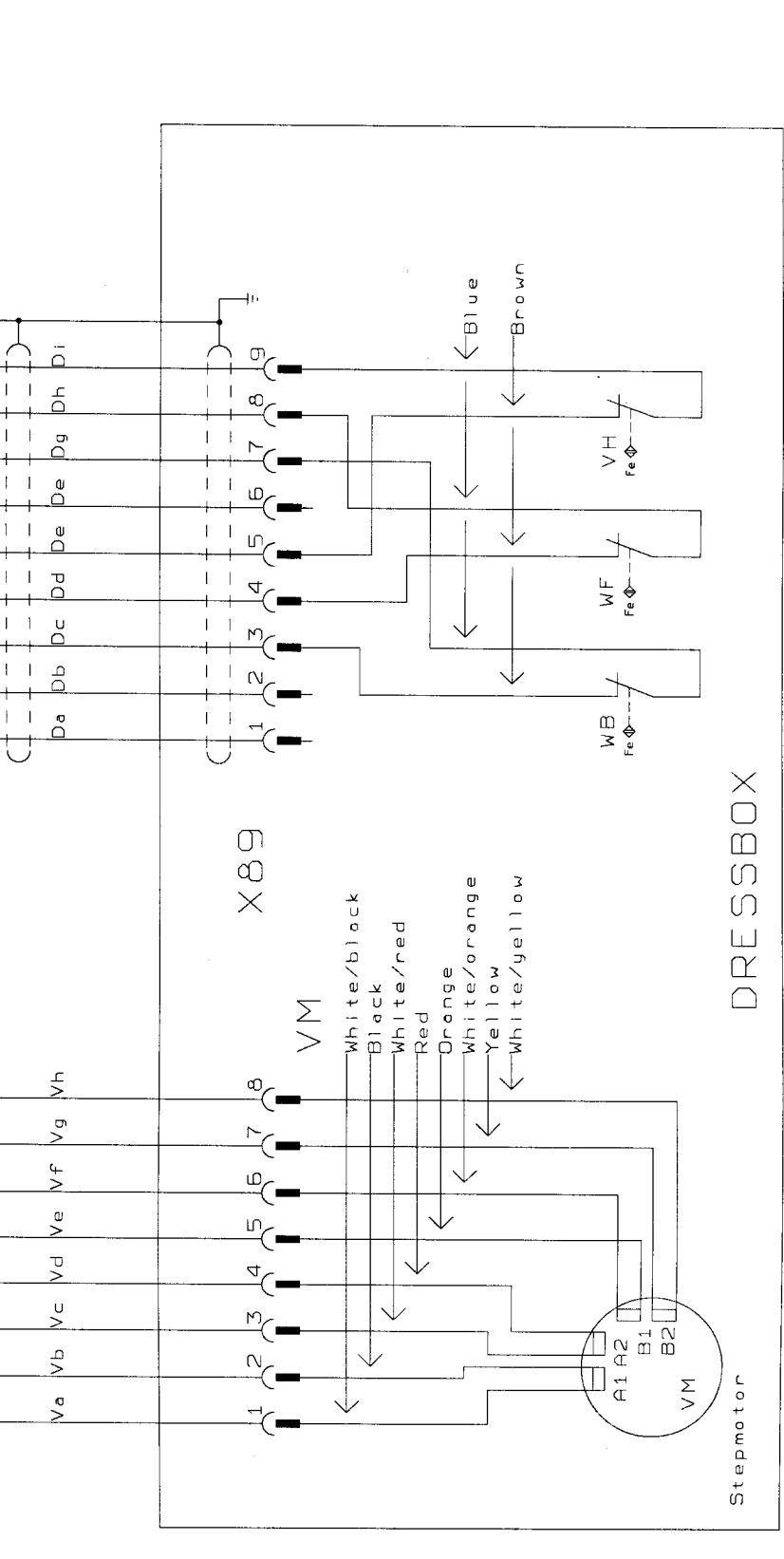
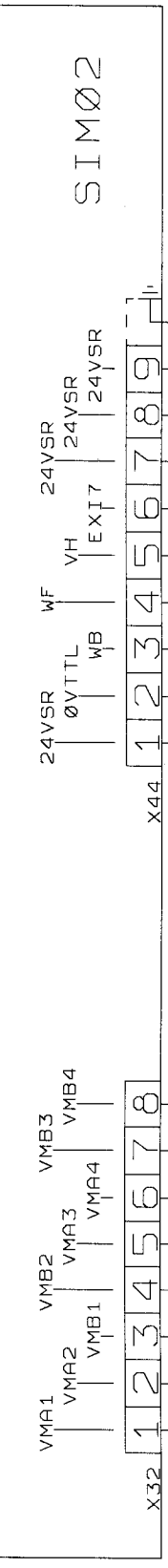

DRESSBOX

JAKOBSEN SURFACE GRINDERS A/S STAMHOLMEN 53 2850 HVIDDRE		V-Axis	
SIZE	FSCM NO	DWG NO	REV
A3		92VPI47#. SCH	3.1
August 5. 2001	SCALE	SHEET	17 OF 27

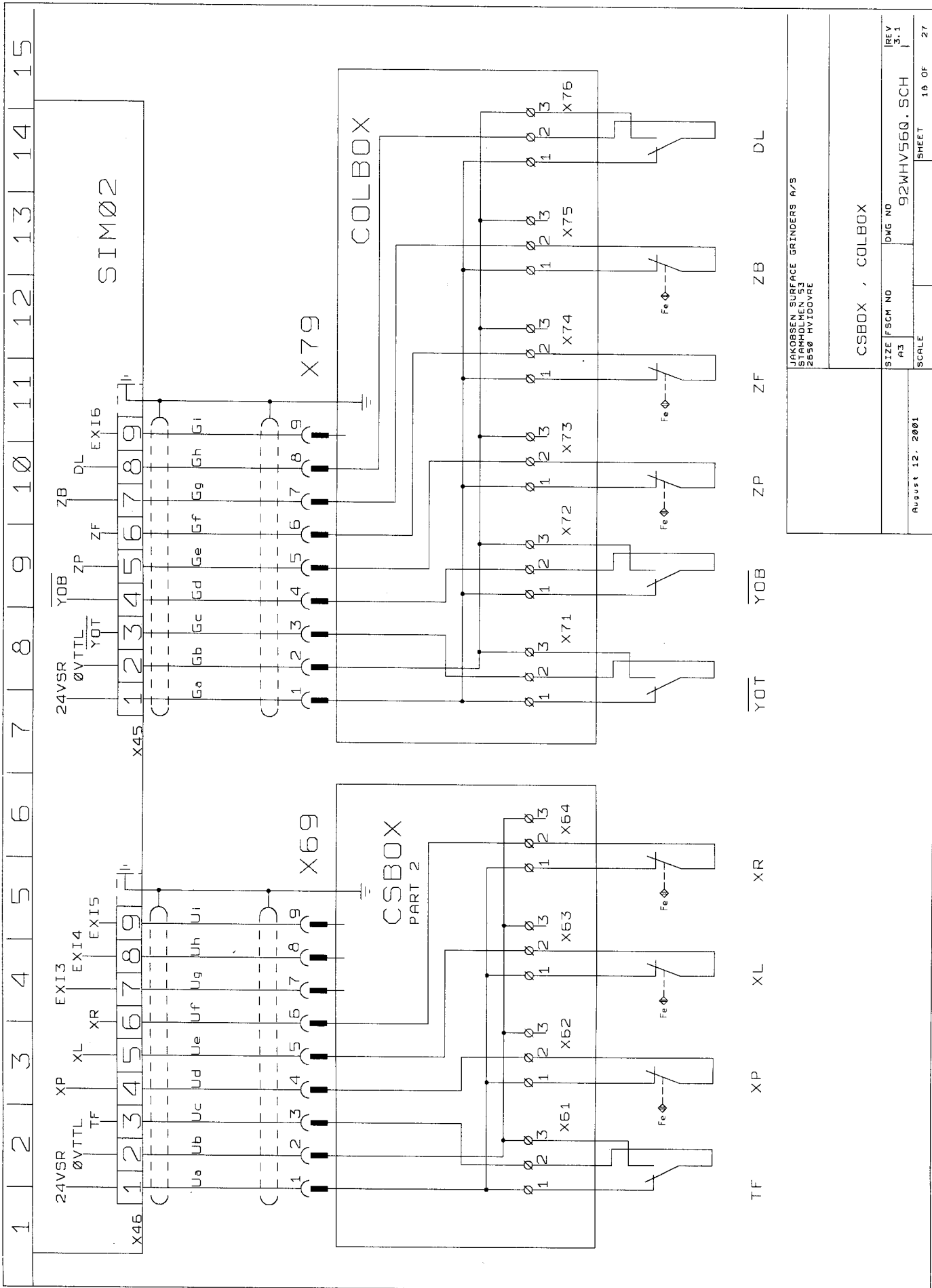

JAKOBSEN SURFACE GRINDERS A/S STAMHOLMEN 53 2650 HVIDOVRE		SIZE A3	FSCM NO	DWG NO 92WHV560.SCH	REV 3.1
August 12, 2001		SCALE		SHEET 16 OF	27
CSBOX , COLBOX					

1 2 3 4 5 6 7 8 9 10 11 12 13 14 15

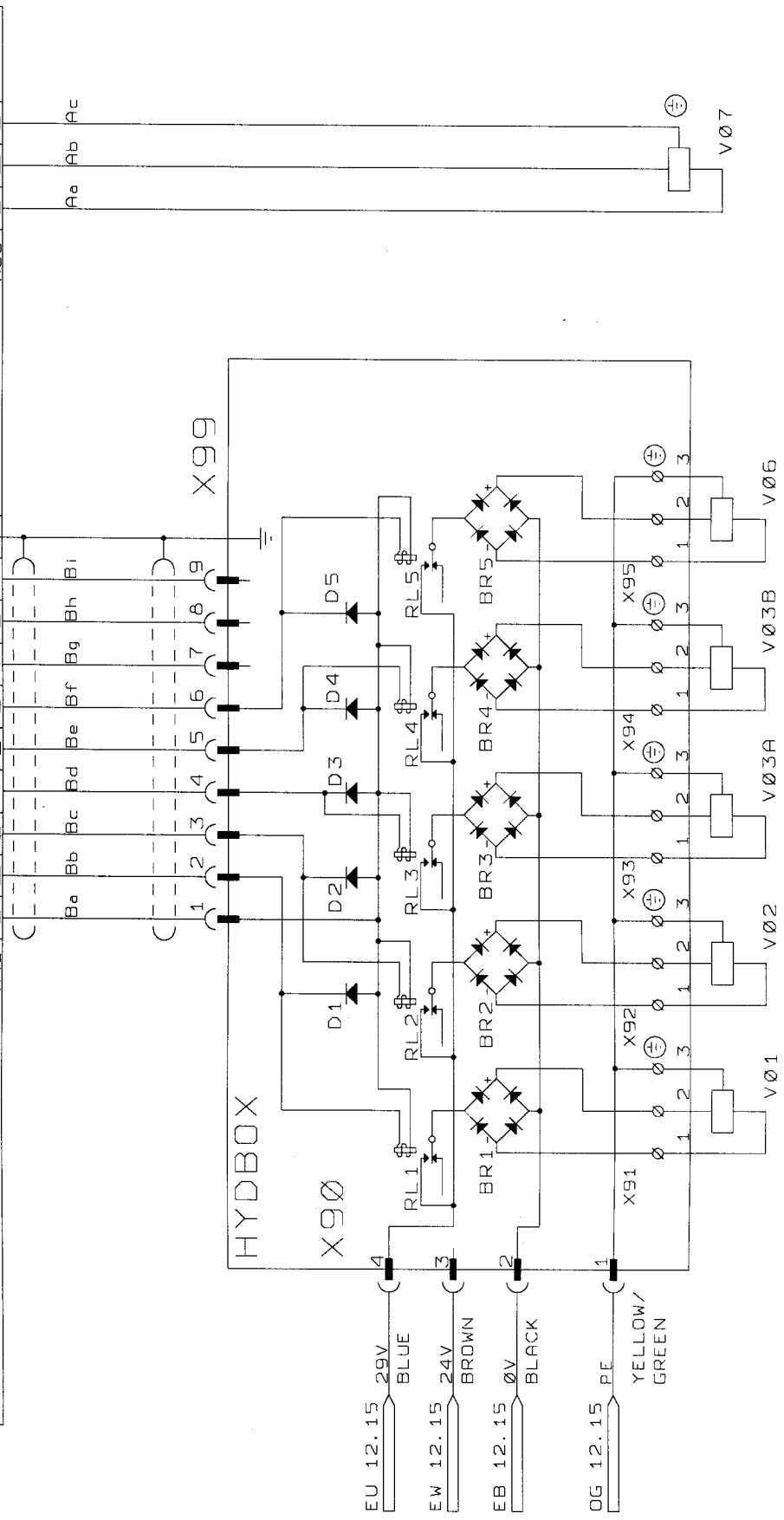
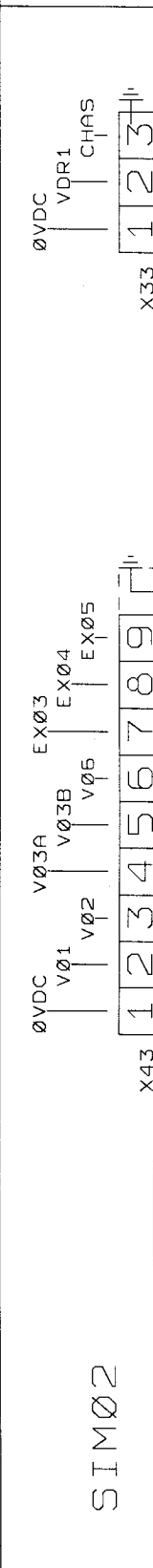

LAKOBSEN SURFACE GRINDERS A/S  
STAMHOLMEN 53  
2850 HVIDOVRE

HYDBOX + V07

August 5. 2001	August 5. 2001	August 5. 2001	August 5. 2001
SCALE	SCALE	SCALE	SCALE
SIZE A3	SIZE A3	SIZE A3	SIZE A3
FSCM NO	FSCM NO	FSCM NO	FSCM NO
DWG NO	DWG NO	DWG NO	DWG NO
92WF7KS8.SCH	92WF7KS8.SCH	92WF7KS8.SCH	92WF7KS8.SCH
REV 3.1	REV 3.1	REV 3.1	REV 3.1
SHEET 19 OF 27	SHEET 19 OF 27	SHEET 19 OF 27	SHEET 19 OF 27

1 2 3 4 5 6 7 8 9 10 11 12 13 14 15

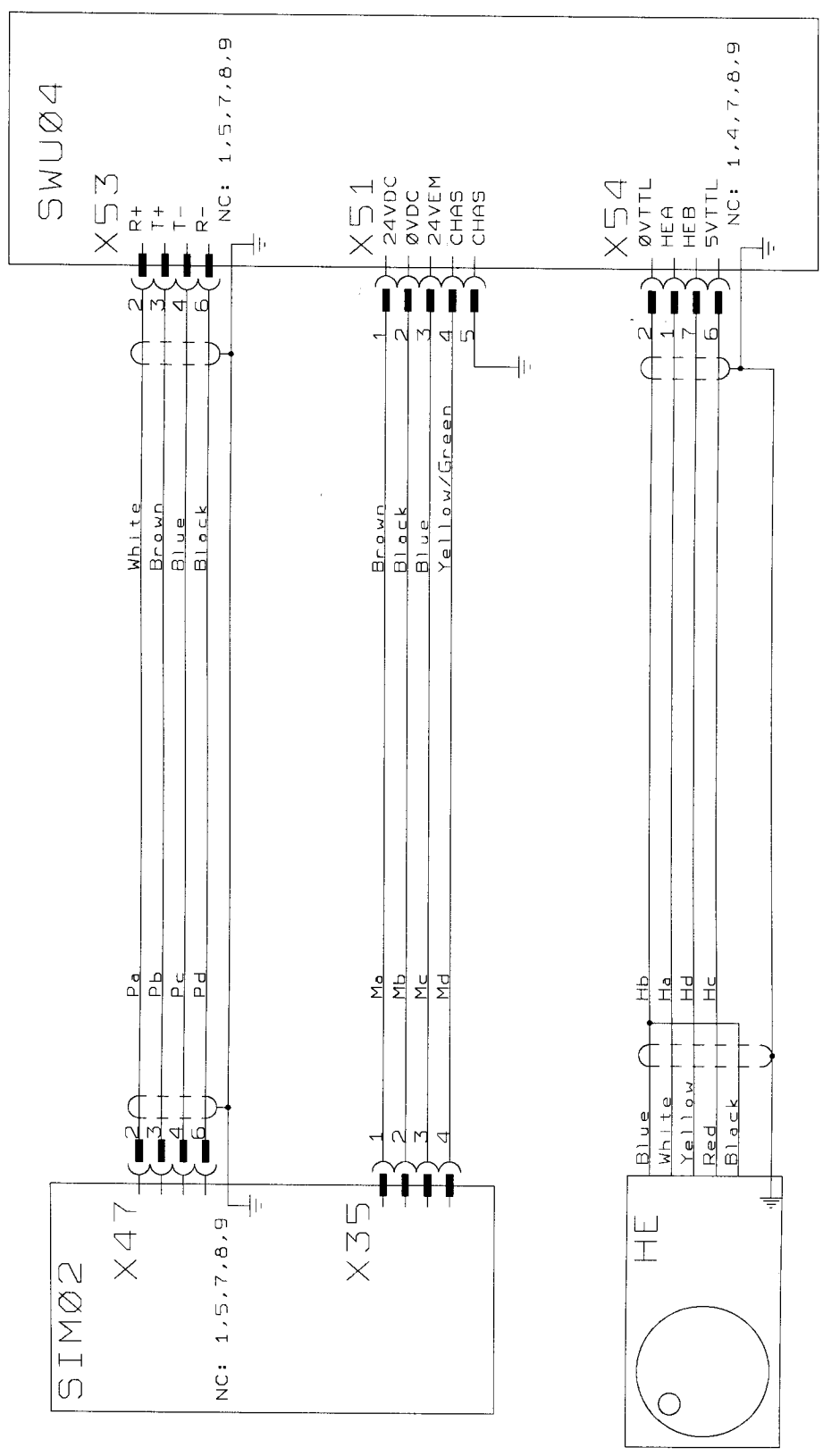

JAKOBSEN SURFACE GRINDERS A/S  
 STAMHOLMEN 51  
 2650 HVIDOVRE

HE + COMCABEL

SIZE	FSCM NO	DWG NO	REV
A3		92072RGC.SCH	3.1
SCALE			SHEET 20 OF 27
August 5. 2001			

SIF03/S1 SIM02/X22

XZDRVP1.2 ZE

	15 D-sub	15 D-sub
X22/01:	I -	1
X22/02:	I +	2
X22/03:	B -	3
X22/04:	B +	4
X22/05:	A -	5
X22/06:	A +	6
X22/07:	TS -	7
X22/08:	TS +	8
X22/09:	+5V	9
X22/10:	A	10
X22/11:	B	11
X22/12:	ØV	12
X22/13:	C	13
X22/14:	+5V	14
X22/15:	ØV	15
X22/16:		
X22/17:		
X22/18:		
X22/19:		
X22/20:		
X22/21:		
X22/22:		
X22/23:		
X22/24:		
X22/25:		

LARSEN SURFACE GRINDERS A/S  
 STAMHOLMEN 53  
 2650 HVIIDVRE  
 TLF. 32 50 14 34

CABLES

August 5, 2001	SCALE	DWG NO	REV
		95UD1FK.SCH	3.1
SHEET		21 OF 27	

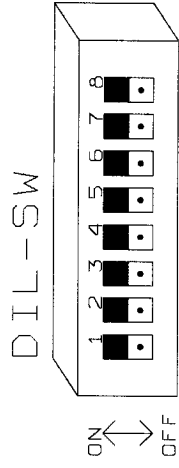

ON \_\_\_\_\_ OFF

- |   |           |          |          |
|---|-----------|----------|----------|
| 1 | INCH      | CHUCK ON | MM       |
| 2 | CHUCK OFF | FEED-R/L | CHUCK ON |
| 3 | FEED-R+L  | DI NO    | FEED-R/L |
| 4 | DI OFF    | Z-NRM    | DI NO    |
| 5 | Z-SPC     | W=DEF    | Z-NRM    |
| 6 | W=Ø       | -        | W=DEF    |
| 7 | -         | -        | -        |
| 8 | -         | -        | -        |

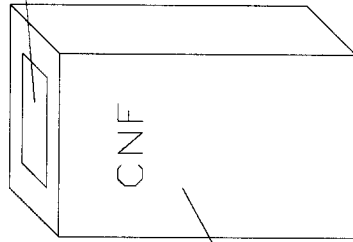

SIMØ2

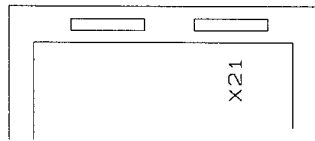

JAKOBSEN SURFACE GRINDERS A/S  
STAMHOLMEN 53  
2650 HVIDOVRE

CNF

August 5, 2001	SCALE	DWG NO	REV
August 5, 2001	A3	924LSA98.SCH	3.1
August 5, 2001	SCALE	SHEET	27
August 5, 2001	SCALE	SHEET	22 OF 27



1 2 3 4 5 6 7 8 9 10 11 12 13 14 15

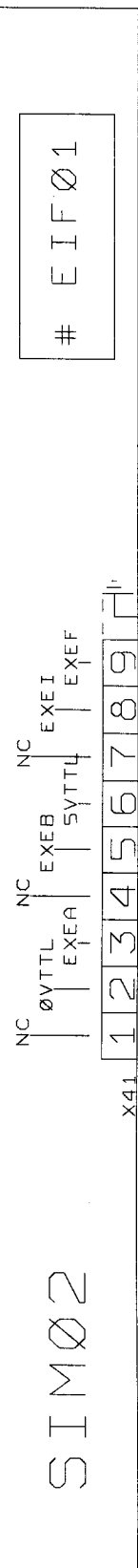

# EIFØ1

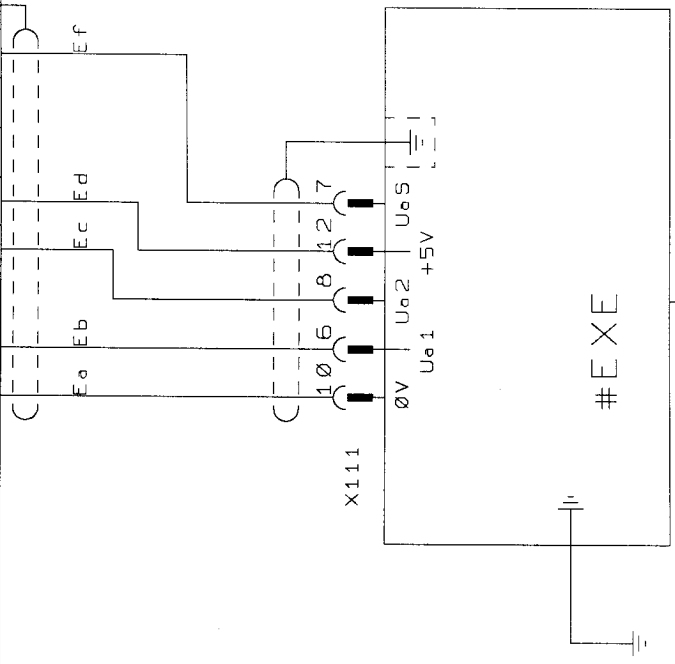

# OPTION		# DI	
JAKOBSEN SURFACE GRINDERS A/S STAMHOLMEN 53 2650 HYDovre			
SIZE	FSCM NO	DWG NO	REV
A3		9240MLØB. SCH	3.1
August 5. 2001	SCALE	SHEET	23 OF 27

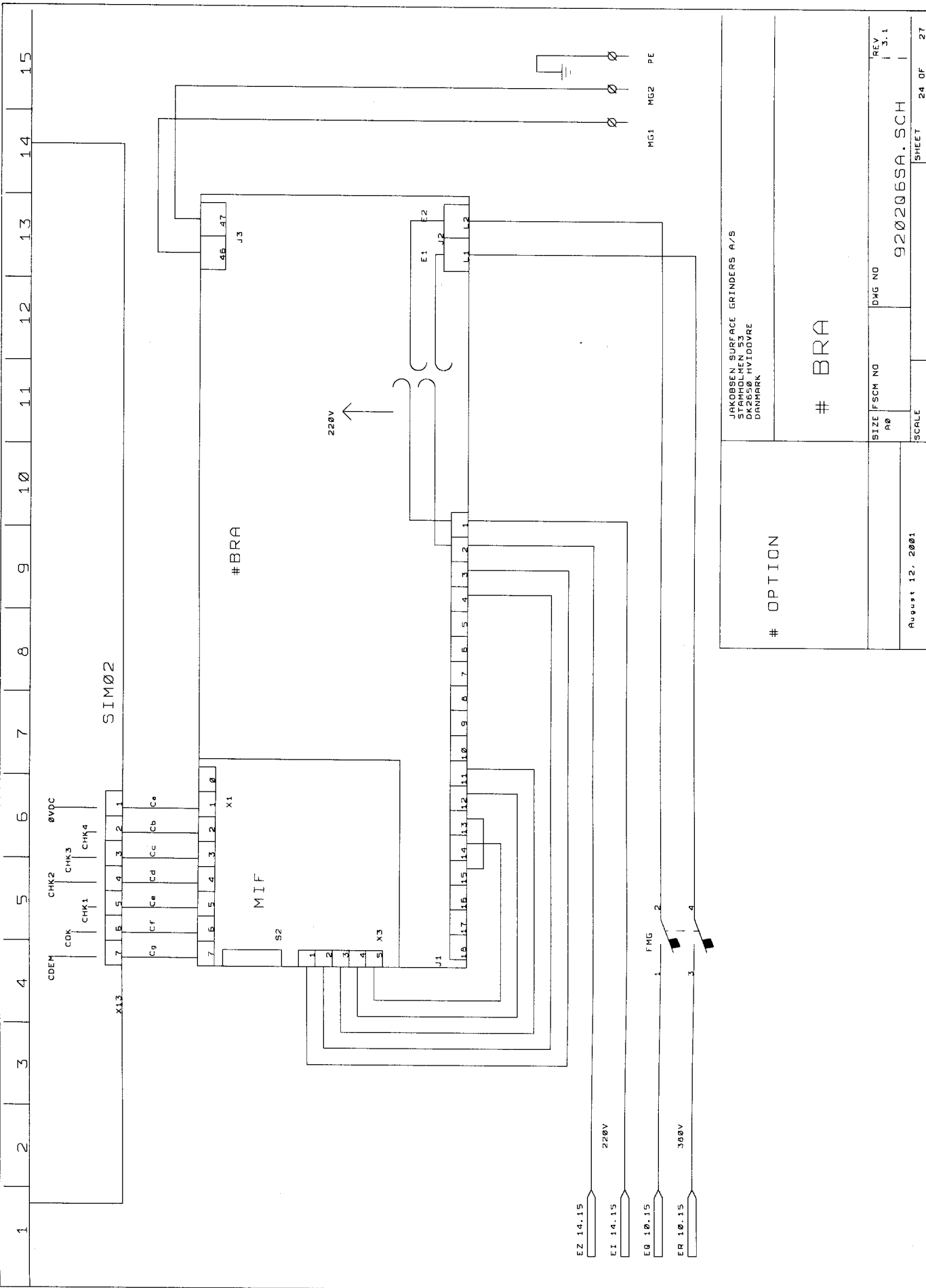

JAKOBSEN SURFACE GRINDERS A/S  
 STAMHOLMEN 53  
 4150 RYDØRE  
 DANMARK

# OPTION

# BRA

SIZE	FSCM NO	DWG NO	REV
A0		92Ø206SA.SCH	3.1
August 12, 2001			SHEET
			24 OF 27

1 2 3 4 5 6 7 8 9 10 11 12 13 14 15

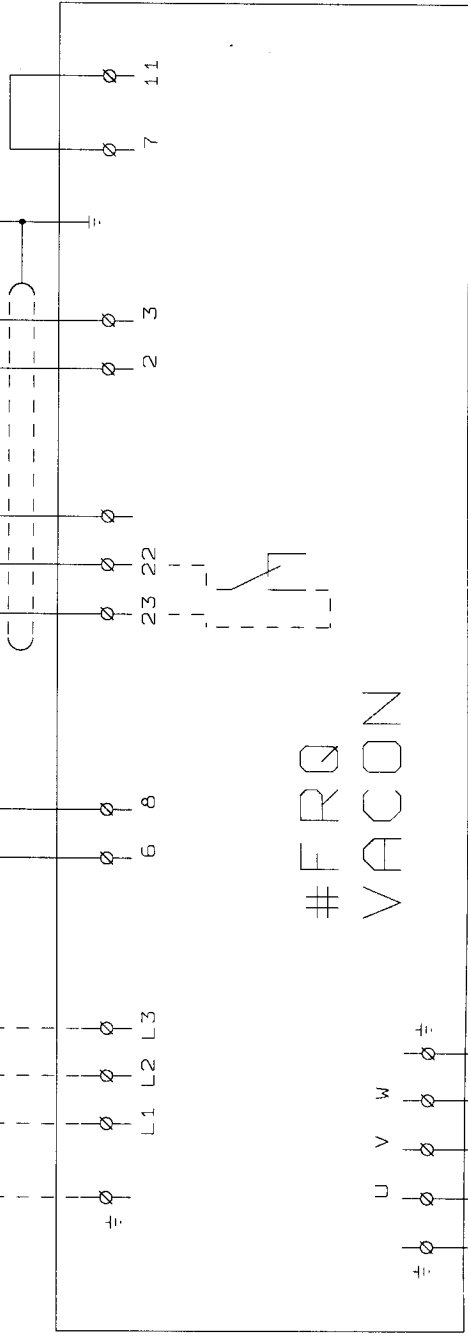
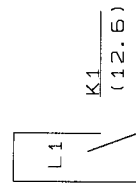
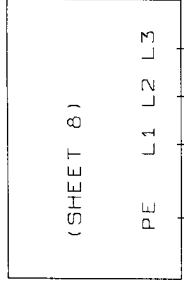
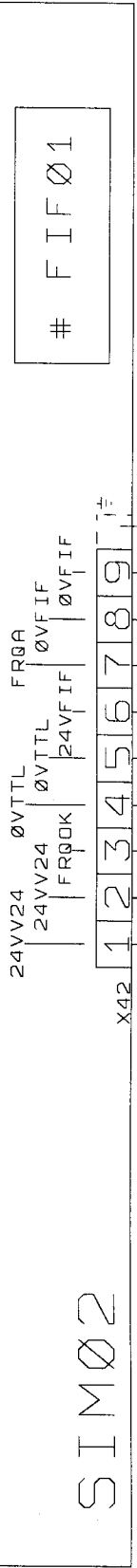

#FRØ  
VACON

# OPTION		JAKOBSEN SURFACE GRINDERS A/S STAMHOLMEN 23 2550 HVIDOVRE	
# FRØ	VACON	SIZE A3	DWG NO 9748S2D.SCH
August 5. 2001	SCALE	REV 3.1	SHEET 25 OF 27

1 | 2 | 3 | 4 | 5 | 6 | 7 | 8 | 9 | 10 | 11 | 12 | 13 | 14 | 15

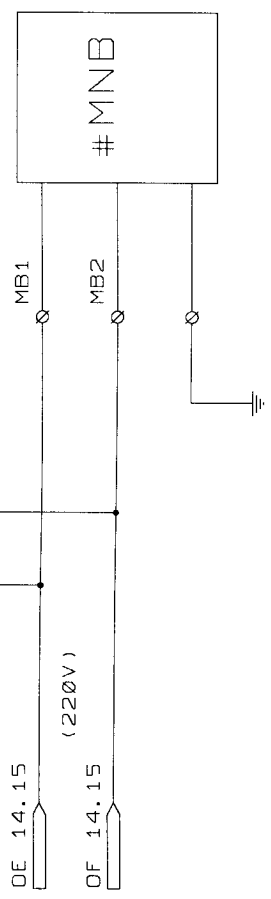
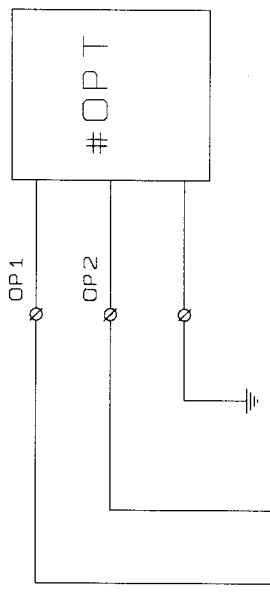
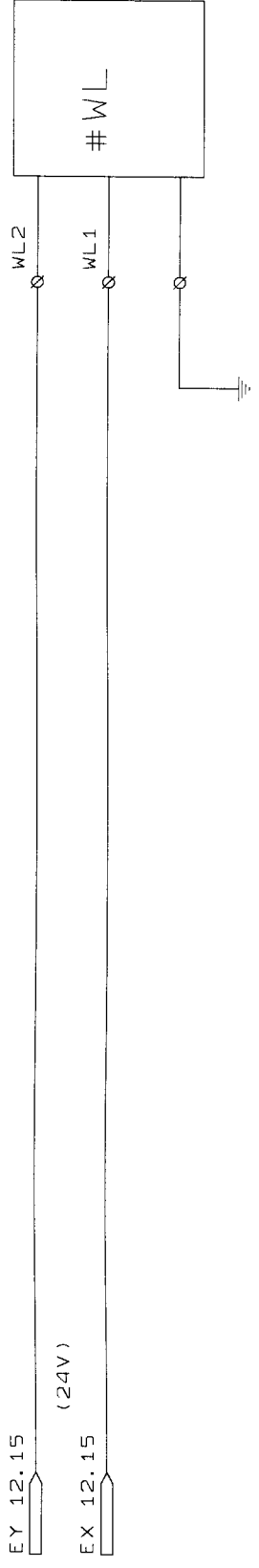

# OPTION		JAKOBSEN SURFACE GRINDERS A/S STAMHOLMEN 53 2650 HVIDOVRE	
SIZE	FSCM NO	DWG NO	REV
A3		95VC86S7. SCH	3.1
August 12, 2001	SCALE	SHEET	27
WL + MNB + OPT			

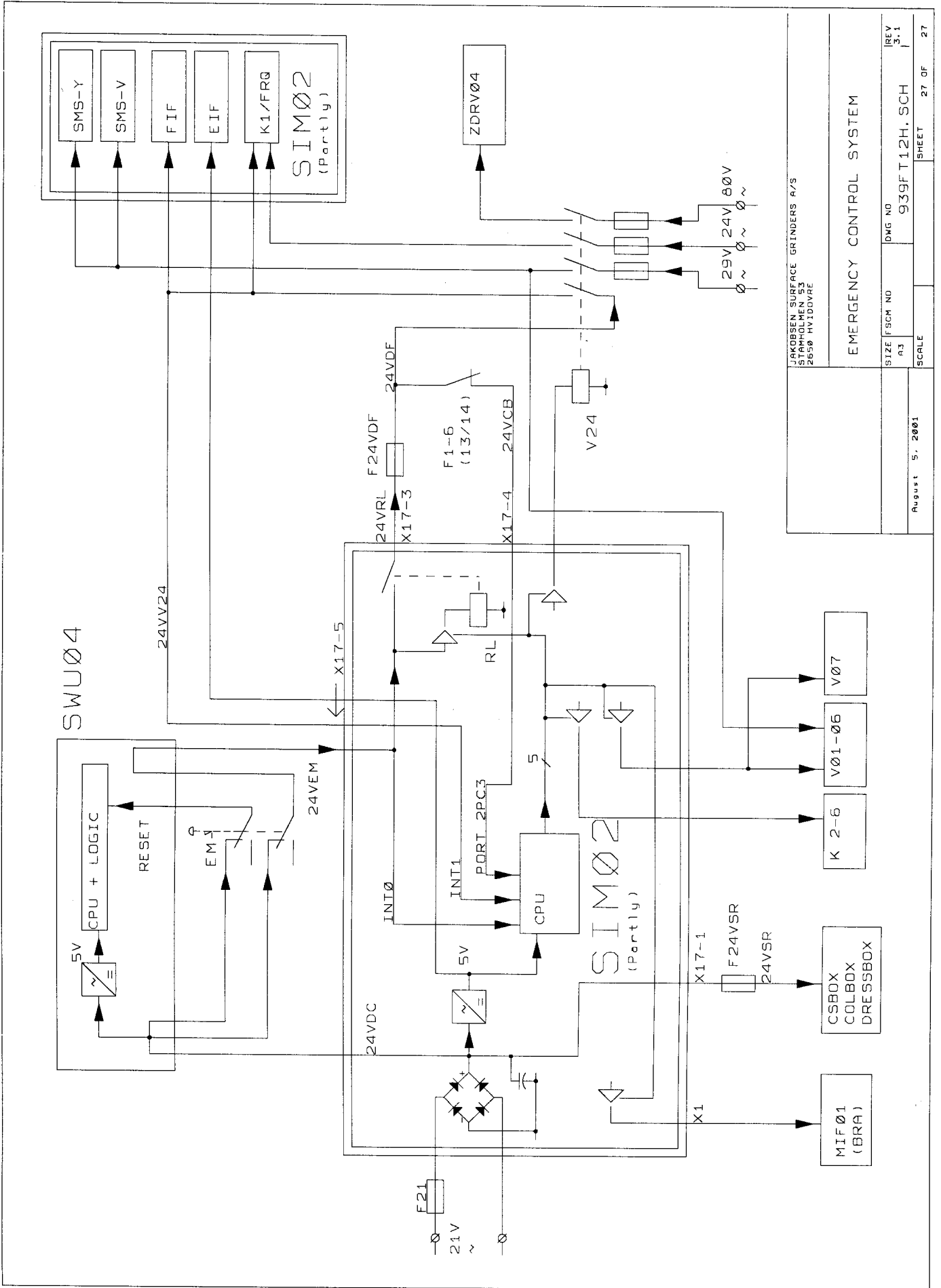

JAKOBSEN SURFACE GRINDERS A/S  
 STAMHOLMEN 53  
 2650 HVIDOVRE

EMERGENCY CONTROL SYSTEM

August 5. 2001	SCALE	F SCM NO	DWG NO	REV
		A3	939FT12H. SCH	3.1
				27 OF 27

**HOVEDKOMPONENTER****MAIN PARTS**

BRA/CHUCK	Magnetplanstyring	Chuckcontrol
CNF	Maskintilpasningsmodul	Configuration module
COLBOX	Samleboks i søjle	Connectionbox in column
CSBOX	Samleboks i mellemslæde	Connectionbox in crosssadle
DI	Digital skala , tværbevægelse	Digital scale, crosssadle
DL	Fastlåsning af afretter	Dresser lock
DRESSBOX	Samleboks på afretter	Connectionbox at dresser
EIF01	Digital skala styrekort in SIM02	Digital scale control board in SIM02
EM	Nødstopafbryder	Emergency stop
EPU	Elektropermanentplan	Electropermanentchuck
EXE	Elektronikbox, digital skala	Electronicbox, digital scale
F1	Motorværn for slibemotor	Circuitbreaker for grindingmotor
F130	Sikring, elektroplan	Fuse, electrochuck
F2	Motorværn for hydraulikpumpemotor	Circuitbreaker for hydraulicpumpmotor
F21	Sikring, 21V vekselstyrestrom	Fuse, 21V AC-controlvoltage
F220	Sikring, 220V, kun intern brug, isoleret	Fuse, 220V, only internal use, isolated
F24	Sikring, 24V veksel, styrestrom	Fuse, 24V AC-controlvoltage
F24VDF (F24VF)	Sikring, 24V følere og switche	Fuse, 24V sensors and switches
F24VSR (24VS)	Sikring ,24V jævn-styrestrom	Fuse, 24V DC-controlvoltage
F29	Sikring, 29V stepmotor vekselstyrestrom	Fuse, 29V AC-controlvoltage for stepmotor
F3	Motorværn for kølevandspumpemotor	Circuitbreaker for Coolantwater pumpmotor
F4	Motorværn for ilgangsmotor	Circuitbreaker for Vertical Rapidfeed motor
F5	Motorværn for kølevandsfilter	Circuitbreaker for Coolantwater filter
F6	Motorværn for aquaseparator	Circuitbreaker for Aquaseparator
F80	Sikring, 80V vekselstrøm for servosystem	Fuse, 80V AC for Servosystem
FAN	Styreskab ventilator	Ventilator, main power panel
FCS	Motorværn, 380V transformatorer	Circuitbreaker, 380V Transformers
FIF01	Frekvensomformer styrekort	Frequencyconverter control board
FMB	Sikring, manobalance	Fuse, Manobalance
FMG	Sikring, elektropermplan	Fuse, Electropermanent
FRQ	Frekvensomformer	Frequencyconverter
HE	Håndhjul	Handwheel
HK-TERMINALS	Hovedklemmer	Mainterminals
HYDBOX	Samleboks på hydraulikpumpestation	Connectionbox, hydraulic pumpstation
K1*	Kontaktor slibemotor, stjernestart	Contactora, Grindingmotor, star starting
KA	Kontaktor slibemotor, trekantstart	Contactora, grindingmotor, triangle starting
K1	Kontaktor slibemotor, direkte start	Contactora, grindingmotor, direct start
K1T	Kontaktor slibemotor, termoforsinket	Contactora, grindingmotor, thermal delay
K2	Kontaktor, hydraulikpumpemotor	Contactora, hydraulic pump motor
K3	Kontaktor, kølevandspumpemotor	Contactora, Coolantwater pump motor
K4A	Kontaktor, ilgangsmotor, op	Contactora, Vertical Rapidfeed motor, up
K4B	Kontaktor, ilgangsmotor, ned	Contactora, Vertical Rapidfeed motor, down
K5	Kontaktor, kølevandsfilter	Contactora, Coolantwater filter
K6	Kontaktor, aquaseparator	Contactora, aquaseparator
KT	Tidsrelæ, slibemotor	Timerelay, grindingmotor
M1	Slibemotor	Grinding motor
M2	Hydraulikpumpemotor	Hydraulic pump motor
M3	Kølevands pumpemotor	Coolantwater pump motor
M4	Ilgangsmotor	Vertical Rapidfeed motor
M5	Kølevandsfilter	Coolantwater filter

M6	Aquaseparator	Aquaseparator
MG1/2	Magnetplan tilslutning	Chuck connection
MIF	Styrekort i magnetplanstyring	Controlboard in chuckcontrol
MNB	Automatisk manobalance	Instrument, Manobalance
OPT	Afretter Optidress	Dresser Optidress
P1-4	Forbindelsesstik servodrev P1 til P4	Connector, Servodrive marked P1 to P4
PE	Betegnelse for sikringsjord	Designation for protective earth
PowerPanel	Hovedtavle	Main power panel
QA	Hovedafbryder	Main power switch
SIF03	Servo interface type 3	Servo interface type 3
SIM02	Elektronikstyring type 02	System Interface Module type 02
SMS	Stepmotorstyring	Stepmotorcontroller
SWU04	Operatør panel type 04	Operator Panel type 04
T1	Transformer, diverse styrestrømme	Transformer, different controlvoltages
T2	Transformator, 80V for servodrev	Transformer, 80V for servodrive
T3	Transformator, 110V magnetplanstyring	Transformer, 110V Chuckcontrol
TF	Kontakt for manuel bordbevægelse	Switch for Table feed
TRAFOS	Transformatorpanel	Transformerpanel
U1	Hovedklemmer fase U, slibemotor	Mainterminal phase U, grindingmotor
U2	Hovedklemmer fase U, hydraulikmotor	Mainterminal phase U, hydraulicmotor
U3	Hovedklemmer fase U, kølevandsmotor	Mainterminal phase U, Coolantwatermotor
U4	Hovedklemmer fase U, ilgangsmotor	Mainterminal phase U, rapidfeed motor
U5	Hovedklemmer fase U, kølevandsfilter	Mainterminal phase U, Coolantwater filter
U6	Hovedklemmer fase U, aquaseparator	Mainterminal phase U, aquaseparator
V01	Ventil, aflastning	Valve, relief
V02	Ventil, start	Valve, start
V03A	Ventil, længdebevægelse, venstre	Valve, lengthmovement, left
V03B	Ventil, længdebevægelse, højre	Valve, lengthmovement, right
V06	Ventil, afretter ud	Valve, dresser out
V07	Ventil, afretter kølevand	Valve, dresser Coolantwater
V1	Hovedklemmer fase V, slibemotor	Mainterminal phase V, grindingmotor
V2	Hovedklemmer fase V, hydraulikmotor	Mainterminal phase V, hydraulicmotor
V3	Hovedklemmer fase V, kølevandsmotor	Mainterminal phase V, Coolantwatermotor
V4	Hovedklemmer fase V, ilgangsmotor	Mainterminal phase V, rapidfeed motor
V5	Hovedklemmer fase V, kølevandsfilter	Mainterminal phase V, Coolantwater filter
V6	Hovedklemmer fase V, aquaseparator	Mainterminal phase V, aquaseparator
V24	Hoved styrestrømsrelæ	Main relay, controlvoltage
V-AXIS	V-akse system	V-axis system
VDR1	Udgangsdriver for ventil V07	Output Driver, valve V07
VH	V-home reference induktive føler	V-home reference inductive sensor
VM	V-akse motor (Stepmotor)	V-axis motor (Steppingmotor)
W1	Hovedklemmer fase W, slibemotor	Mainterminal phase W, grindingmotor
W2	Hovedklemmer fase W, Hydraulikmotor	Mainterminal phase W, hydraulicmotor
W3	Hovedklemmer fase W, kølevandsmotor	Mainterminal phase W, Coolantwatermotor
W4	Hovedklemmer fase W, ilgangsmotor	Mainterminal phase W, rapidfeed motor
W5	Hovedklemmer fase W, kølevandsfilter	Mainterminal phase W, Coolantwater filter
W6	Hovedklemmer fase W, aquaseparator	Mainterminal phase W, aquaseparator
WB	Afretter bag, induktive føler (W-akse)	Dresser back, inductive sensor (W-axis)
WF	Afretter frem, induktive føler (W-akse)	Dresser front, inductive sensor (W-axis)
WL	Arbejdslampe, Halogen 24V	Working lamp, Halogen 24V
X1	Hovedklemmer fase X, slibemotor	Mainterminal phase X, grindingmotor
XL	Bord venstre, induktive føler (X-akse)	Table left, inductive sensor (X-axis)
XP	Bord parkering, induktive føler (X-akse)	Table parking, inductive sensor (X-axis)

XR	Bord højre, induktive føler (X-akse)	Table right, inductive sensor (X-axis)
Y1	Hovedklemmer fase Y, slibemotor	Mainterminal phase Y, grindingmotor
Y-AXIS	Y-akse motorsystem	Y-axis motorsystem
YE	Y-akse encoder	Y-axis encoder
YM	Y-akse motor (Stepmotor)	Y-axis motor (Steppermotor)
YOB	Y-akse overløb bund, afbryder	Y-axis overrun, bottom, switch
YOT	Y-akse overløb top, afbryder	Y-axis overrun, top, switch
Z1	Hovedklemmer fase Z, slibemotor	Mainterminal phase Z, grindingmotor
Z-AXIS	Z-akse motorsystem	Z-axis motorsystem
ZB	Z-akse, bagerste induktiv føler	Z-axis, back inductive sensor
ZDRV04	Z-akse servomotorstyring	Z-axis servomotorcontroller
ZE	Z-akse servomotorencoder	Z-axis servomotorencoder
ZF	Z-akse, foreste induktiv føler	Z-axis, front inductive sensor
ZM	Z-akse servomotor	Z-axis servomotor
ZOB	Y-akse overløb bagerst, afbryder	Y-axis overtravel, back, switch
ZOF	Y-akse overløb foreste, afbryder	Y-axis overtravel, foreste, switch
ZP	Tværbævegelse, parkering induktiv føler	Crossmovement, parking inductive sensor



**DEL-KOMPONENTER****SUB-COMPONENTS**

25 D-sub	25 pol. forbindelsesstik, type D-sub	25 pin D-sub connector
A1-2	Terminalmarkinger for kontaktorer o.lign.	Terminalmarkings for connectors etc.
B1-2	Terminalmarking for kontaktorer o.lign.	Terminalmarking for connectors etc.
BR1-5	Brokoblet ensrettere, hydraulikventiler	Bridgerectifiers, hydraulic valves
COMCABEL	Kommunikationkabel SWU04/SIM02	Communicationcable SWU04/SIM02
ControlSystem	Styresystem	Main system
CPU	Decentral computerenhed	Decentral computerunit
D1-5	Afkoblingsdioder, hydraulikventiler	Decoupling diode, hydraulic valves
DIL-SW	Rækkeomskifter,	Dual-in-line switch
FEED R+L	Tilspænding i højre og venstre side	Feed in right and left turnaround
FEED R/L	Tilspænding kun i højre eller venstre side	Feed only left or right side
L1-3	Fasemarkering, hovedstrøm	Phasemarking, main supply
L1-3	Tilgangsmarkering, kontaktorer	Inputconnections, contactors
LEDS	Lysdioder på servodrev	Lightemitting diodes, servodrive
LOGIC	Integreret logikkredsløb	Integrated Logic circuit
PORT 2PC3	Intern computerindgang	Internal computerinput
Pri	Primær forbindelse til transformatorer	Primary connections, transformers
R	Fase markering, servomotor	Phase marking, servomotor
RESET	Nulstilling af computer enhed	Zerostetting of computer unit
RL1-5	Relæer, hydraulikventiler	Relays, hydraulic valves
RS485	RS-485 specificeret kommunikation	RS485 specified communication
S	Fase markering, servomotor	Phase marking, servomotor
S1	Stikmarkering	Connectormarking
T	Fase markering, servomotor	Phase marking, servomotor
T1-3	Afgangsmarkering, kontaktorer	Outputconnections, contactors
W=0	Afretnings værdi nullet ved opstart	Dressing value Zeroed at startup
W=DEF	Afretnings værdi = default ved opstart	Dressing value = default at startup
VACON	Frekvensomformer type VACON	Frequency converter type VACON
VM A1-2	V-akse stepmotorspoler	V-axis steppermotorcoils
VM B1-2	V-akse stepmotorspoler	V-axis steppermotorcoils
XZDRVP1	Stik P1 på servodrevet	Connector P1, Servodrive
XZDRVP2	Stik P2 på servodrevet	Connector P2, Servodrive
YM A1-2	Y-akse stepmotorspoler	Y-axis steppingmotorcoils
YM B1-2	Y-akse stepmotorspoler	Y-axis steppingmotorcoils
Z-NRM	Normalindstilling for Z-funktion	Normal setting for Z-function
Z-SPC	Mini/mikrostep funktion for Z-bevægelse	Mini/microstep setting for Z-movement

<b>SIGNALBETEGNELSER</b>		<b>SIGNALDESIGNATION</b>
+5V	5V intern spændingsbetegnelse	5V Internal supplydesignation
0V	0 ref. for 24V/29V	0 ref. for 24V/29V
0V21	0 ref. For 21V	0 ref. For 21V
0V24	0 ref. For 24V	0 ref. For 24V
0V29	0 ref. For 29V	0 ref. For 29V
0V80	0 ref. For 80V	0 ref. For 80V
0VAC	0 ref. for 21VAC	0 ref. for 21VAC
0VDC	0 ref for 24V jævnspænding	0 ref. for 24V DC
0VFIF	Intern 0 ref. for frekvensomformer	Internal 0 ref. for frequency converter
0VTTL	0 ref. for intern logikforsyning	0 ref. for internal logic supply
21VAC	21V vekselsp. for ensretning	21V AC for rectifier
21V	21V vekselspænding	21V AC
220V	220V intern vekselspænding	220V AC, internal
24FIF	Intern styrestrøm for Frekv.omf.	Internal controlvoltage for Freq. conv.
24V	24V vekselspænding	24V AC
24VCB	24V motorværnskontrol	24V circuit Breaker check
24VDC	24V jævnsp. styrestrøm før Nødafbr.	24V DC controlvolt. before EM-switch
24VEM	24V jævnsp. styrestrøm efter Nødafbr.	24V DC controlvolt. after EM-switch
24VRL	24V styrespænding	24V controlvoltage
24VSR	24V styrespænding	24V controlvoltage
24VV24	24V styrespænding	24V controlvoltage
29V	29V styresp. til stepmotorstyring + Hyd.	29V controlvolt. for Stepmotorcontr. + Hyd.
5V	5V intern spændingsbetegnelse	5V Internal supplydesignation
5VTTL	5V intern spændingsbetegnelse	5V Internal supplydesignation
80V	80V vekselsp. for Servodrev	80V AC for servodrive
A	Intern encoderbetegnelse	Internal encoderdesignation
A+/-	Intern encoderbetegnelse	Internal encoderdesignation
AC	Vekselspændingbetegnelse	Alternate current designation
B	Intern encoderbetegnelse	Internal encoderdesignation
B+/-	Intern encoderbetegnelse	Internal encoderdesignation
C	Intern encoderbetegnelse	Internal encoderdesignation
CDEM	Afmagnetiseringsignal	Demagnetizen signal
CHAS	Chassis markering	Chassis marking
CHK1	Magnetiseringsniveau 1	Magnetization level 1
CHK2	Magnetiseringsniveau 2	Magnetization level 2
CHK3	Magnetiseringsniveau 3	Magnetization level 3
CHK4	Magnetiseringsniveau 4	Magnetization level 4
COK	Magnetplan aktiveret, bekræftiget	Chuck magnetized, verified
DC	Jævnspændingsbetegnelse	Direct current designation
EXEA	Digital skala signal A	Digital scale signal A
EXEB	Digital skala signal B	Digital scale signal B
EXEF	Digital skala signal F	Digital scale signal F
EXEI	Digital skala signal I	Digital scale signal I
EXI3-7	SIM02 ekstra indgang 0 - 7	SIM02 additional input 0 - 7
EXO3-5	SIM02 ekstra udgang 3 - 5	SIM02 additional output 3 - 5
F24VF	Sikringsbeskyttet F24VDF sp.	Fused F24VDF volt.
F24VS	Sikringsbeskyttet F24VSR sp.	Fused F24VSR volt
FRQA	Frekvensomformer analogsignal	Frequencyconverter analogsignal
FRQOK	Frekvensomformer er-kørende-signal	Frequency converter running signal
FRQS	Frekvensomformer start/stop signal	Frequency converter start/stopsignal

Gnd	Jord betegnelse	Ground designation
HEA/B	Interne håndhjulsencodersignaler	Internal Handwheelencoder sig.
I+/-	Intern encoderbetegnelse	Internal encoderdesignation
INT0/1	Interne computer brydesignaler	Internal computer interrupt sig.
K1/FRQS	K1 eller FRQ aktiveringssignal	K1 or FRQ, activationsignal
K1ON	Kontakter K1 aktiveret	Contactactor K1 activated (ON)
K1RL	K1 styrestrøm	K1 controlvoltage
K2ON	Kontakter K2 aktiveret	Contactactor K2 activated (ON)
K3ON	Kontakter K3 aktiveret	Contactactor K3 activated (ON)
MB1/2	220V for MNB	220V for MNB
OP1/2	220V for Optidress	220V for Optidress
R+/-	Balanceret modtagesignal	Differential receive signal
SIFD0-7	Servo kommando datasignaler	Servo command datasignals
SIFG0/1	Servo kommando datasignaler	Servo command datasignals
T+/-	Balanceret sendersignal	Differential transmitter signal
TAC1/2	380V til transformatorer	380V for transformers
TS+/-	Intern encoderbetegnelse	Internal encoderdesignation
Ua0-S	Intern encoderbetegnelse	Internal encoderdesignation
VMA1-4	V-akse motorterminaler	V-axis motorterminals
VMB1-4	V-akse motorterminaler	V-axis motorterminals
WL1/2	Hovedklemmer , 24V arbejdslampe	Mainterminals, 24V working lamp
YEA/B	Y-akse encodersignaler	Y-axis encodersignals
YMA1-4	Y-akse motorterminaler	Y-axis motorterminals
YMB1-4	Y-akse motorterminaler	Y-axis motorterminals
ZDRVA	Intern servokommando, Encoder	Internal servocommand, Encoder
ZDRVB	Intern servokommando, Encoder	Internal servocommand, Encoder
ZDRVE	Intern servokommando	Internal servocommand
ZDRVF	Intern servokommando	Internal servocommand

**ALMENE FORKORTELSER**

~	Symbol for vekselstrøm
#	Markering af ekstraudstyr
--	Betegnelse for omvendt funktion
...0,5A...	Markering af strøm i ampere
Aa...Ya	Diverse diagramreferencer
ADJ.	Forskellige justeringsmuligheder
Beige	Farven beige
Black	Farven sort
BLOCKSCHEMATIC	Blokdiagram
Blue	Farven blå
Brown	Farven brun
CABLES	Kabler
EA-EL	Diverse diagramreferencer
EMERGENCY	Nødstopfunktion
EO-EZ	Diverse diagramreferencer
Fe	Markering induktiv føler
FUSES	Sikringer
Green	Farven grøn
INCH	Tommer (amerikanske)
LAYOUT	Oversigt
MAIN POWER	Hovedstrøm
MM	Millimetre
N	Nul fase (Neutral)
n.c./NC:	Betegnelse for ingen forbindelse
NO	Nej, negativ funktion
NORM.	Normal funktion
OB-OF	Diverse diagramreferencer
OFF	Afbrudt, slukket
ON	Tændt,
OPTION (OPT)	Ekstraudstyr
Orange	Farven orange
Part	Del af ...
Partly	Partiel
Pink	Farven lyserød
Red	Farven rød
SHEET ....	Side ...
SPEC.	Speciel funktion
STEPMOTOR	Skridtmotor
V24CHECK	Specifik 24V kontrolsignal
White	Farven hvid
X.....	Betegnelse for stik + reference
Yellow	Farven Gul

**COMMON ABBREVIATIONS**

~	Sign for alternate current
#	Marking of optional equipment
--	Designation for reverse funktion
...0,5A...	Marking, current in amps
Aa...Ya	Different schematic references
ADJ.	Different adjusting possibilities
Beige	The colour beige
Black	The colour black
BLOCKSCHEMATIC	Blockschematic
Blue	The colour blue
Brown	The colour brown
CABLES	Cables
EA-EL	Different schematic references
EMERGENCY	Emergency stop funktion
EO-EZ	Different schematic references
Fe	Marking, inductive sensor
FUSES	Fuses
Green	The colour green
INCH	Inches (american)
LAYOUT	Layout
MAIN POWER	Main Power
MM	Millimeters
N	Zero phase (Neutral)
n.c./NC:	No connection designation
NO	No, negative funktion
NORM.	Normal funktion
OB-OF	Different schematic references
OFF	Off, disconnected
ON	On
OPTION (OPT)	Options
Orange	The colour orange
Part	Part of ....
Partly	Partly
Pink	The colour pink
Red	The colour red
SHEET ....	Sheet....
SPEC.	Special funktion
STEPMOTOR	Stepping motor
V24CHECK	Specific 24V checksignal
White	The colour white
X.....	Designation for connectors + reference
Yellow	The colour yellow